

Libretto uso e manutenzione
Use and maintenance manual
Manuel d'utilisation et entretien
Bedienungs- und Wartungsanleitung

DUCATI *MULTISTRADA*

1100S

1100

DUCATI *MULTISTRADA*

1100S

1100

E

We would like to welcome you among Ducati enthusiasts, and congratulate you on your excellent choice of motorcycle. We are sure that you will use your Ducati for longer journeys as well as short daily trips, but however you use your motorcycle, Ducati Motor Holding s.p.a wishes you an enjoyable ride.

We are continuously working to improve our Technical Assistance service. For this reason, we recommend that you follow strictly the instructions in this manual, especially those regarding the running-in period. In this way, you can be sure your Ducati motorcycle will continue to be a pleasure to ride.

For repairs or advice, please contact one of our authorized service centres.

We also provide an information service for all Ducati owners and enthusiasts for any advice and suggestions you might need.

Enjoy the ride!



Notes

Ducati Motor Holding S.p.A. cannot accept any liability for errors that may have occurred in the preparation of this manual. All information in the manual is valid at the time of going to print. Ducati Motor Holding S.p.A. reserves the right to make any modifications required due to the ongoing development of their products.

For safety and reliability, to avoid invalidating the warranty and to maintain the value of your motorcycle, use only original Ducati spare parts.



Warning

This manual is an integral part of the motorcycle and, if ownership of the motorcycle is transferred to a third party, the manual must be handed over to the new owner.

Table of contents

General indications 6

- Warranty 6
- Symbols 6
- Useful road safety information 7
- Riding with a full load 8
- Identification data 10

Controls 11

- Position of the motorcycle controls 11
- Instrument panel 12
- LCD – Main functions 13
- LCD – How to set/display parameters 15
- Display backlight 21
- Brightness of warning lights 21
- Lights auto-switch off function 21
- The immobilizer system 22
- Keys 22
- Code card 23
- Procedure to override the immobilizer using the throttle twistgrip 24
- Duplicate keys 25
- Ignition switch and steering lock 26
- Left-hand handlebar switch 27
- Clutch lever 28
- Right-hand handlebar switch 29

- Throttle twistgrip 29
- Front brake lever 30
- Rear brake pedal 31
- Gearchange pedal 31
- Adjusting the position of the gearchange and rear brake pedals 32

Main components and devices 34

- Position on motorcycle 34
- Fuel tank filler cap 35
- Passenger seat lock and helmet holder 36
- Document compartment lock 37
- Sidestand 38
- Front fork adjuster 39
- Rear shock absorber adjusters 41
- Rear view mirror adjustment 43
- Adjusting the rear ride height 44

Riding the motorcycle 46

- Running-in precautions 46
- Pre-ride checks 48
- Starting the engine 49
- Moving off 51
- Braking 51
- Stopping the motorcycle 52
- Parking 52
- Refuelling 53
- Toolkit and accessories 54

Main Use and Maintenance Operations 55

Removing the fairing panels 55
Checking the brake and clutch fluid level 60
Checking the brake pads for wear 62
Lubricating cables and joints 63
Adjustment of the throttle cable free play 64
Charging the battery 65
Checking the chain tension 66
Lubricating the drive chain 67
Changing the high and low beam headlight bulbs 68
Changing the front turn indicator bulbs 72
Changing the rear turn indicator bulbs 73
Changing the number plate light and brake light bulbs 74
Headlight aim 76
Tubeless tyres 78
Checking the engine oil level 80
Cleaning and renewing the spark plugs 81
General cleaning 82
Storing the motorcycle 83
Important notes 83

Maintenance 84

Programmed maintenance plan: operations to be carried out by the dealer 84
Programmed maintenance plan: operations to be carried out by the dealer 87

Technical data 88

Overall dimensions (mm) 88
Weights 88
Fluids and lubricants 89
Engine 90

Timing system 90
Performance data 91
Spark plugs 91
Fuel system 91
Exhaust system 91
Transmission 92
Brakes 93
Frame 94
Wheels 94
Tyres 94
Suspension 95
Available colours 95
Electrical system 96

For United States of America version Only 101

Reporting of safety defects 101
Safety warnings 101
Noise emission warranty 101
Noise and exhaust emission control system information 101
Tampering warning 102
Riding safety 103
Protective apparel 104
Vehicle identification number (VIN) 104
Label location 105
California evaporation emission system 107
Ducati limited warranty on emission control system 107

Routine maintenance record 110

General indications

E

Warranty

In your own interest, and in order to guarantee product reliability, you are strongly advised to refer to a Ducati Dealer or Authorized Workshop for servicing that requires any particular technical expertise.

Our highly qualified staff have access to the specialised tools required to perform any servicing job to the highest professional standards, using only Ducati original spare parts as the best guarantee for perfect interchangeability, smooth running and long service life.

All Ducati motorcycles come with a Warranty Booklet. However, the warranty does not apply to motorcycles used in competitions. If any motorcycle part is tampered with, modified, or replaced with parts other than original Ducati spare parts during the warranty period, the warranty is automatically invalidated.

Symbols

Ducati Motor Holding S.p.A. advises you to read this manual carefully in order to familiarise yourself with your motorcycle. If in doubt, please contact a Ducati Dealer or Authorized Service Centre. You will find the information in the manual useful on trips (which Ducati Motor Holding S.p.A. hopes will be smooth and enjoyable), and it will help you obtain top performance from your motorcycle for a long time. This booklet uses a set of symbols with special meanings:



Warning

Failure to comply with these instructions may put you at risk, and could lead to severe injury or even death.



Important

Risk of damage to the motorcycle and/or its components.



Notes

Additional information about the current operation.

The terms **right** and **left** are relative to the direction of running of the motorcycle.

Useful road safety information



Warning

Read this section before riding your motorcycle.

Many accidents are the result of the inexperience of the rider. Always make sure you have your licence with you; you need a valid licence that entitles you to ride a motorcycle.

Do not lend your motorcycle to persons who are inexperienced or do not hold a valid licence.

Riders and passengers must **always** wear appropriate clothing and a safety helmet.

Do not wear loose clothes or accessories that could become tangled in the controls or limit your field of vision.

Never start or run the engine in an enclosed space.

Exhaust gases are toxic and may lead to loss of consciousness or even death within a short time.

The rider should keep his/her feet on the footrests when the motorcycle is in motion.

Always hold the handlebars firmly with both hands so you will be ready for sudden changes in direction or in the road surface. The pillion passenger should **always** hold on to the grab rail on the rear seat with both hands.

Obey the legal requirements and observe national and local regulations.

Always respect the speed limits where these are indicated, and **never** exceed the speed allowed by the particular visibility, road and traffic conditions.

Always signal your intention to turn or change lane in good time, using the appropriate turn signal indicators.

Be sure you are clearly visible and avoid riding within the blind spot of a vehicle in front of you.

Be very careful at road junctions, or when riding in areas near exits from private land or car parks, or on the slip roads to motorways.

Always turn off the engine when refuelling. Be extremely careful not to spill fuel on the engine or on the exhaust pipe when refuelling.

Do not smoke when refuelling.

While refuelling, it is possible to inhale noxious fuel vapours. Should any fuel drops be spilled on your skin or clothing, immediately wash with soap and water and change your clothing.

Always remove the key if leaving your motorcycle unattended.

The engine, exhaust pipes and silencers remain hot for a long time.



Warning

The exhaust system might be hot, even after engine is switched off; take special care not to touch exhaust system with any part of your body and do not park the motorcycle next to inflammable material (wood, leaves etc.).

Park your motorcycle where no one is likely to knock against it, and use the sidestand.

Never park on uneven or soft ground, or your motorcycle may fall over.

Riding with a full load

Your motorcycle is designed for travelling over long distances with a full load in complete safety. Even weight distribution is critical for maintaining safety standards and to avoid getting into difficulties when making sudden manoeuvres or riding on bumpy roads.

E

Important

Avoid riding at speeds in excess of 120 km/h with panniers fitted. Reduce your speed even further if your tyres are worn, on poor road surfaces, or in poor visibility.

Information on load capacity

The total weight of the motorcycle in running order with rider, luggage and additional accessories should not exceed 410 kg.

The total weight of luggage must never exceed 23 kg, divided as follows (fig. 1):
9 kg max. per side pannier;
5 kg max. in the tank bag.

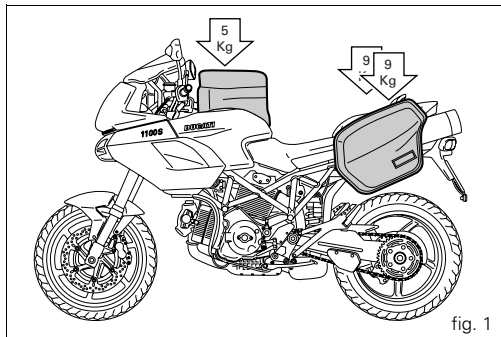

fig. 1

Arrange your luggage or heavy accessories in the lowest possible position and as close to centre of the motorcycle as possible.

Secure the luggage firmly to the motorcycle structure. Luggage incorrectly secured may cause the motorcycle to become unstable.

Never attach bulky or heavy objects to the top yoke or front mudguard, as this would cause dangerous instability.

Do not insert objects into gaps in the frame, where they could interfere with moving parts.

When fitting panniers (available from the Ducati parts service):

arrange personal effects and accessories according to weight and distribute them evenly in both panniers; lock the panniers with the key provided.

Make sure the tyres are inflated to the proper pressure indicated at page 78 and that they are in good condition.

Identification data

All Ducati motorcycles have two identification numbers, one for the frame (fig. 2) and one for the engine (fig. 3).

Frame number

Engine number



Notes

These numbers indicate the motorcycle model and should be quoted when ordering spare parts.

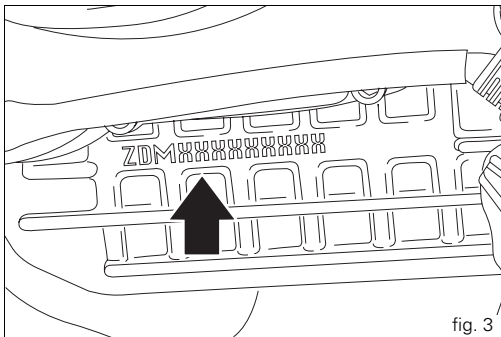
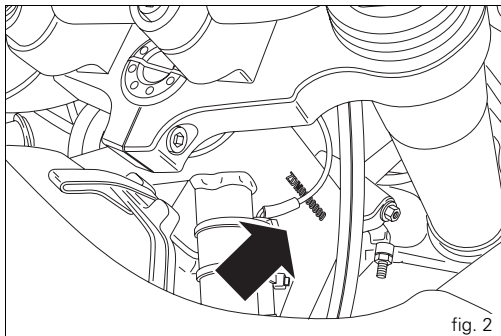

Controls



Warning

This section shows the position and function of the controls used to drive the motorcycle. Be sure to read this information carefully before you use the controls.

Position of the motorcycle controls (fig. 4)

- 1) Instrument panel.
- 2) Key-operated ignition switch and steering lock.
- 3) Left-hand handlebar switch.
- 4) Right-hand handlebar switch.
- 5) Throttle twistgrip.
- 6) Clutch lever.
- 7) Front brake lever.
- 8) Rear brake pedal.
- 9) Gearchange pedal.

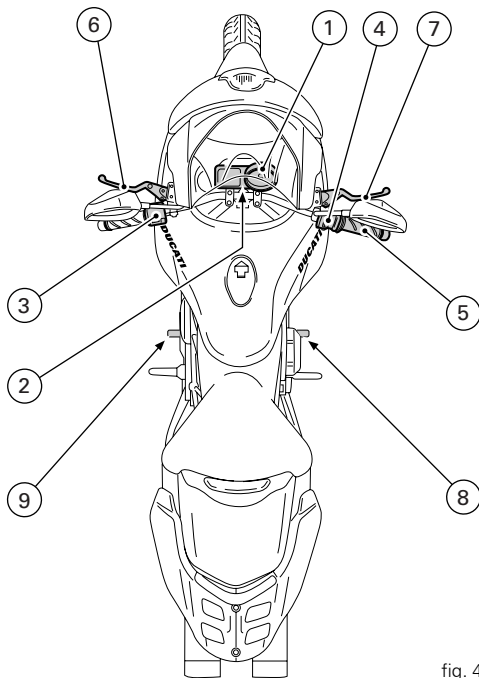

fig. 4

Instrument panel

1) **LCD**, (see page 13).

2) **Control buttons A and B**.

These buttons are used to view and set instrument panel parameters.

3) **IMMO immobilizer indicator**  (amber).

The indicator stays on when key code is wrong or not recognized, and flashes after an error signal from the immobilizer system has been reset by performing the immobilizer override procedure using the throttle twistgrip (see page 24).

Important

The instrument panel is part of the on-board electronic injection/ignition system diagnostics.

The related menus are for use by trained personnel only.

If you accidentally access this function, turn the key to **OFF** and have the motorcycle inspected at an authorized Ducati Service Centre.

4) **Tachometer** (rpm).

Indicates engine revs per minute.

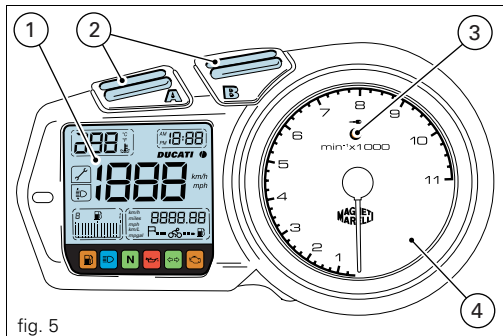

fig. 5

LCD – Main functions



Warning

Any adjustments to the instrument panel must only be carried out when the motorcycle is stationary. Never operate the instrument panel controls while riding the motorcycle.

1) **Oil temperature indicator.**

Indicates the oil temperature.



Important

Stop riding if the temperature reaches the maximum value, otherwise the engine might be damaged.

2) **Clock.**

3) **Speedometer.**

Shows motorcycle road speed.

4) **Auxiliary display.**

Displays, in sequence: total distance travelled, trip distance travelled, fuel trip counter, average speed, current fuel consumption, average fuel consumption, remaining range.

5) **EOBD light (amber).**

This light is lit steadily if the engine control unit has found errors and has therefore blocked the engine.

The light is also used as an indicator during the immobilizer override procedure using the throttle twistgrip. When no errors are present, the light should come on when the ignition switch is set to **ON** and should go out after a few seconds (normally after 1.8-2 sec.).

6) **Turn indicator light** ⇄ (green).

Flashes when a turn signal is on.

7) **Engine oil pressure light** ⚙️ (red).

Illuminates when engine oil pressure is too low. This light must illuminate when ignition is switched to **ON** and must go out a few seconds after the engine starts. It may illuminate briefly when the engine is very hot, however it should go out as the engine revs up.

Important

If this light (7) stays on, stop the engine or it may be severely damaged.

8) **Neutral light (green).**

Illuminates when the gearbox is in neutral.

9) **High beam warning light** ⚡ (blue)

Comes on when high beam is on.

10) **EOBD light** 🚗 (amber).

Comes on when there are about 3 litres of fuel left in the tank.

11) **Fuel display.**

This function shows the fuel level in the motorcycle fuel tank. When the last segment remains lit (flashing) the low fuel light (10) will illuminate.

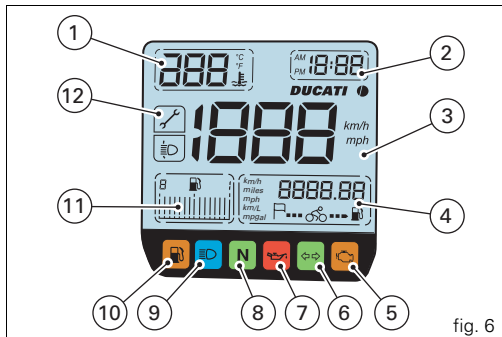

fig. 6

12) **Service indicator.**

The indicator (⚙️) illuminates to signal when a service is due. The indicator continues to flash for 50 km (31 mi) after the ignition has been switched on. After this the indicator will be steadily illuminated. When the indicator starts flashing, contact your dealer or authorised service centre.

LCD – How to set/display parameters

When the engine is started (key from **OFF** to **ON** or **Key-ON**) the instrument panel performs a **Check** of all the instrumentation: dials, display and indicators (fig. 7).

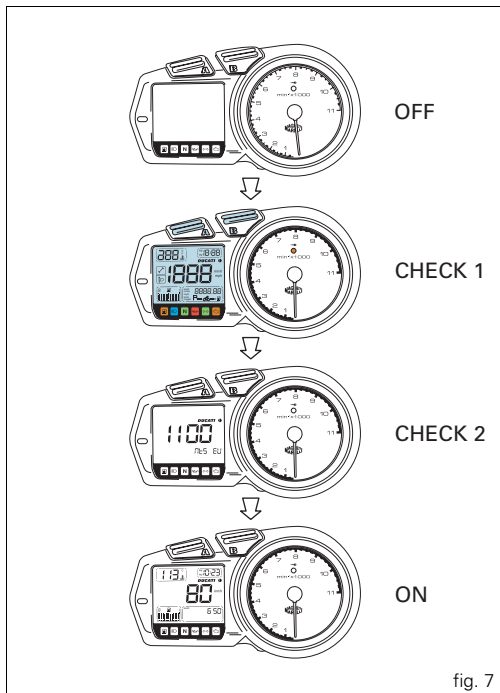

Oil temperature indicator (fig. 8)

Gives engine coolant temperature.

If the engine oil temperature is below or equal to +39 °C / 102.2 °F, "LO" flashes on the display.

If the temperature is between +40 °C/104 °F and +170 °C/ 338 °F, the numerical value will be shown on the display.

If the engine oil temperature is greater than or equal to +171 °C / 339.8 °F, the word "HI" flashes on the display.



Notes

If the temperature sensor becomes disconnected, the display shows flashing blank lines " - - - ".

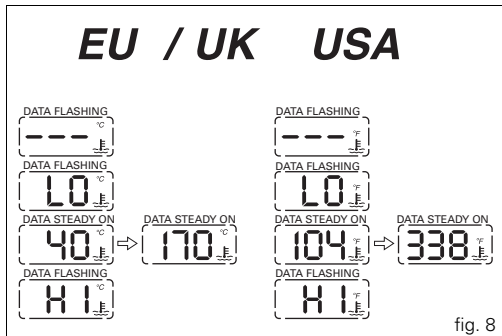

fig. 8

Clock setting

Press button **(A, fig. 5)** for 2 seconds. "AM" flashes. Press button **(B, fig. 5)**, to switch to "PM". Press button **(B)** again to return to "AM". Press button **(A)** to confirm selection and enter the hours setting mode. The hour digits flash. Set hours using the button **(B)**. Press the button **(A)** to confirm and enter the minutes setting mode. Set minutes using the button **(B)**. Hold down button **(B)** for more than 5 seconds to fast scroll through the minutes. Press button **(A)** to confirm, exit clock setting mode, and return to normal display mode.

Accessing the additional display functions (fig. 9)

Press button **(B, fig. 5)** with the ignition key turned to **ON** to scroll through the following display functions:

- Odometer
- Trip counter
- Average speed
- Current fuel consumption
- Average fuel consumption
- Remaining range
- Fuel trip counter (if activated)

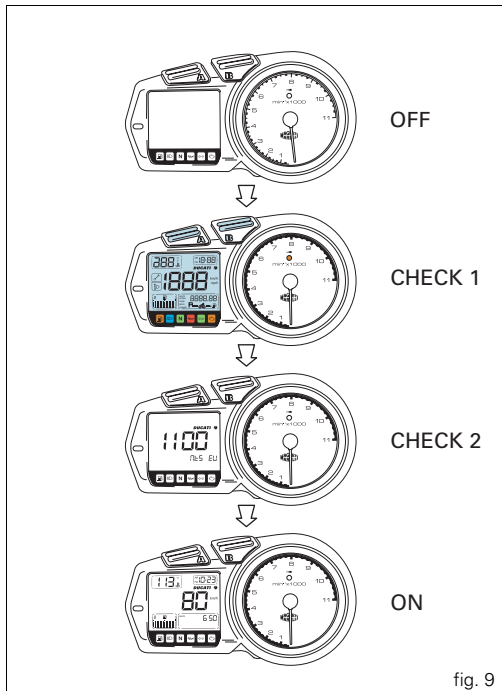

fig. 9

Odometer function (fig. 10)

Indicates the total distance travelled.

Trip counter function (fig. 10)

Indicates the distance travelled since last reset. The trip counter can be reset at any time by accessing the relative display function and pressing button **A** fig. 5 for at least 2 seconds. When the trip counter reaches 9999.9 km (or miles) it resets itself automatically.

When the trip counter is reset, the following parameters are also reset: average speed, average consumption, and fuel used.

Fuel trip counter function (fig. 10)

Indicates the distance travelled since illumination of the fuel reserve warning light (10, fig. 6).

The display will automatically switch from the odometer to the fuel trip mode and start to count the distance travelled from that point.

Average speed function (fig. 10)

Shows the average road speed of the motorcycle.

The average speed is calculated starting from the most recent trip counter reset.

When the motorcycle speed reaches 280 km/h (174 mph) the display shows a series of lines " - - - ".

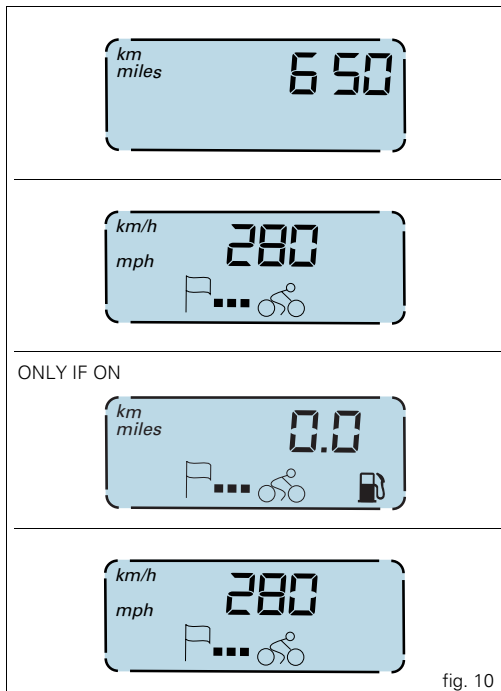

fig. 10

Current fuel consumption function (fig. 11)

When the motorcycle is in motion with the engine running the display will show a numerical value corresponding to the current fuel consumption. If the motorcycle is stopped with the engine running the display will show fixed lines “- - -”. With the engine stopped and the motorcycle at a standstill the display shows “0.0”.

Average fuel consumption function (fig. 11)

When the motorcycle is in motion with the engine running the display will show a numerical value corresponding to the average fuel consumption. When the trip counter is zero reset, the display will show three lines “- - -”; the value will be updated once the bike has travelled 2 km. When the motorcycle is stationary, or stationary with the engine running, the latest value to be recorded will remain on the display until it is updated.

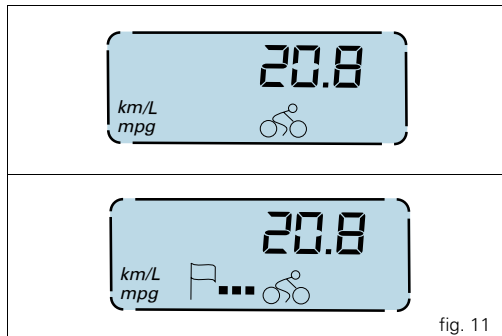

fig. 11

Remaining range function (fig. 12)

Displays how many kilometres or miles the motorcycle can travel on the remaining fuel. When the motorcycle is stationary, or stationary with the engine running, the latest value to be recorded will remain on the display until it is updated. With the display set to this function, if the FUEL RESERVE warning light (10, fig. 6) comes on, the display reads out blank lines “- - -” for as long as the warning light remains on.

Notes

The display is updated every 10 seconds.

Fuel level function (fig. 12)

This function shows the amount of fuel remaining in the motorcycle fuel tank. If the FUEL RESERVE warning light (10, fig. 6) comes on, the display will show the last bar and the petrol pump symbol will start flashing.

If the fuel reserve warning light comes on:

3 litres of fuel still remaining in the tank.

If the FUEL RESERVE warning light (10, fig. 6) comes on, the display will show the last bar “- - -” and the petrol pump symbol will start flashing. the display (4, fig. 6) will switch to the fuel trip counter function and indicate the distance travelled from that point.

Notes

This model of motorcycle has a particularly long fuel tank. Fuel level readings may therefore be slightly inaccurate if the bike is ridden for extended periods up or down hills.

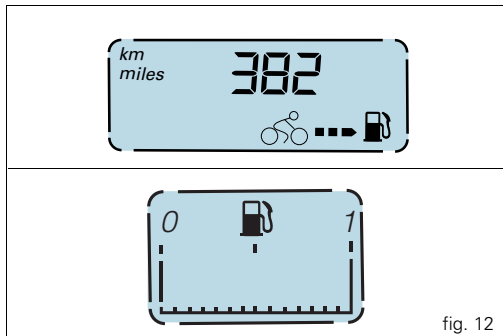

fig. 12

Display backlight

The instrument panel backlight is switched on only if the parking lights or low/high beam is on.

In this case the instrument panel, using sensors that measure ambient temperature and light intensity, automatically turn the backlight on or off.

Brightness of warning lights

This function is on only if the parking lights or the low/high beam headlight is turned on.

The brightness of warning lights is adjusted automatically by the instrument panel according to the level of external light detected.

Lights auto-switch off function

This function helps reduce battery use by automatically switching off the headlight.

The device is triggered in two cases:

- in the first case, if you turn the key from OFF to ON and do not start the engine. within 60 seconds the headlight is turned off and will be turned on again only at next key OFF/ key ON.
- in the second case, after riding the motorcycle with the lights on, if the engine is killed using the ENGINE STOP switch (2, fig. 19). In this case, the headlight will be turned off 60 seconds after stopping the engine and will be only turned on again the next time the engine is started.



Notes

When the engine is started, the system turns off the headlights and only turns them back on again when the engine has started or when the starter button is released (3, fig. 19).

The immobilizer system

For additional anti-theft protection, the motorcycle is equipped with an IMMOBILIZER, an electronic system that locks the engine automatically whenever the ignition switch is turned off.

In the handgrip of each ignition key is an electronic device that modulates the signal sent by a special antenna in the switch during start-up. The modulated signal represents the “password” (which is changed at each start-up) by which the ECU recognizes the ignition key. The ECU will only allow the engine to start if it recognises this password.

Keys (fig. 13)

The owner receives a set of keys, comprising:

- 1 red key (A)

The red key is a service tool and is part of the motorcycle’s immobilizer system. It contains the code of the immobilizer system and should not be used for normal everyday use of your motorcycle. Your dealer may ask you to produce the red key in order to carry out certain service operations.

For security reasons, the red key cannot be replaced. In cases where the red key is required for servicing purposes and the owner is unable to produce it, it will be necessary to renew the motorcycle’s electronic control unit, instrument panel and ignition switch assembly, and the cost of these operations will be met by the owner. It is therefore important to keep the red key in a safe place.

- 2 black keys (B)



Warning

The red key (A) has a rubber sleeve to keep it in perfect condition, and prevent contact with other keys. Never remove this protection unless absolutely necessary.

The B keys are the keys for normal use, and are used to:

- start the engine;
- open the fuel tank filler plug;
- open the document compartment cover;
- open the passenger seat lock.

The A key performs all the same functions as the B keys and it can also be used to reset and re-program other black keys if necessary.

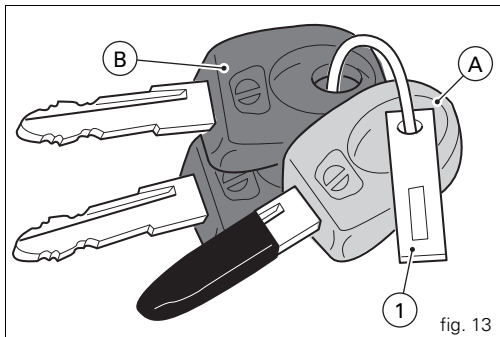

fig. 13



Warning

Sharp knocks can damage the electronic components inside the key.



Notes

The three keys have a small tag (1) attached, which shows their identification number.



Warning

Keep the keys separate, and store the tag (1) and key A in a safe place. It is also recommended to use always the same black key to start the motorcycle.

Code card

A CODE CARD (fig. 14) is delivered with the keys, showing the electronic code (A, fig. 15) that must be used if the engine is locked by the immobilizer and consequently does not start when the key is turned to **ON**.



Warning

Keep the CODE CARD in a safe place. It is advisable to always carry the electronic code shown on the CODE CARD with you when using the motorcycle, in case it is necessary to override the engine immobilizer by means of the procedure using the throttle twistgrip (see page 24). In case of faulty immobilizer system, the following procedure gives the chance to disable "engine block" function - signalled by the amber EOBD warning light that comes on (5, fig. 6). This operation is only possible if the electronic code indicated on the code card is known.

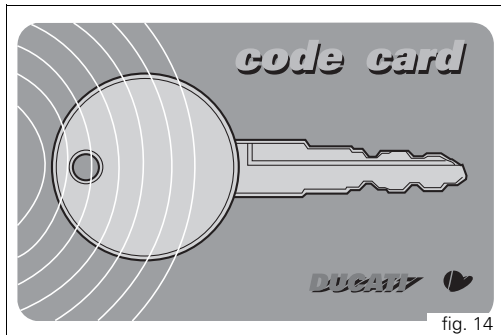

fig. 14

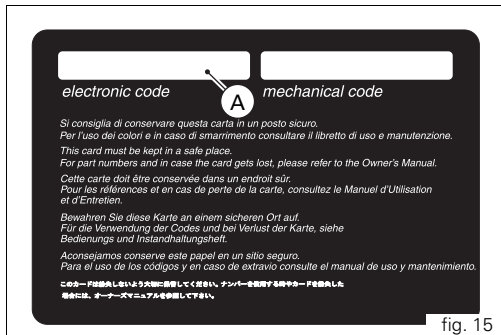

fig. 15

Procedure to override the immobilizer using the throttle twistgrip

- 1) Turn the key to **ON**, then turn the twistgrip to fully open the throttle and hold it open.

The **EOBD** warning light (5, fig. 6) will go off after 8 seconds.

- 2) Release the throttle as soon as the **EOBD** warning light turns off.

- 3) The **EOBD** warning light will light up again and start flashing. Now enter the electronic release code shown on the CODE CARD given to the customer when the motorcycle was handed over by the dealer.

- 4) Count a number of flashes of the **EOBD** light equivalent to the first number of the secret code. Open the throttle twistgrip, keep fully open for 2 seconds, then release. The digit entered is acknowledged, and the EOBD light comes on and stays on for the pre-set time of 4 seconds. Repeat the operation until you have entered the final digit. If no operation is performed with the throttle twistgrip, the **EOBD** light will flash 20 times and then illuminate steadily. In this case, repeat the procedure from step (1).

- 5) When you release the throttle grip, if the code has been entered correctly the following two cases may occur:
 - A) the **EOBD** light starts flashing to indicate that engine starting is now enabled. The light switches off after 4 seconds, or if engine speed exceeds the threshold value of 1000 rpm.
 - B) the **IMMO** warning light (3, fig. 5) flashes until the engine speed rises above 1000 rpm, or until the engine is re-started.
- 6) If the code is NOT entered correctly, both the **EOBD** and **IMMO** lights stay on and the procedure can be repeated starting again from step 2 as many times as necessary.



Notes

If you release the twistgrip too soon, the warning light will come on again. Return the ignition key to **OFF** and repeat the procedure from step 1.

Operation

When the ignition key is turned from **ON** to **OFF**, the immobilizer system activates the engine lock. When the ignition key is turned from **OFF** to **ON (Key-ON)** to start the engine:

- 1) if the ECU recognises the code, the IMMO light (3, fig. 5) on the instrument panel will flash briefly. This means that the immobilizer system has recognised the key code and enabled engine ignition. When you press the  engine start button (2, fig. 19), the engine will start up;
- 2) if the IMMO light stays on, it means that the code has not been recognised. When this is the case, turn the ignition key back to **OFF** and then to **ON** again. If the engine still does not start, try with another black key. If the engine still does not start, contact the DUCATI Service network.
- 3) If the IMMO light keeps flashing, this means that an error signal from the immobilizer system has been cleared (e.g. with the override procedure using the throttle twistgrip).

Important

Always use the same key throughout the procedure. Otherwise, the system might be prevented from recognizing the code of the key being used.

Duplicate keys

If you need duplicate keys, contact the DUCATI Service network with all the keys you have left and your CODE CARD.

DUCATI Service will program new keys and re-program your original keys (up to a maximum of 8 keys) DUCATI Service may ask for proof that you are the legitimate owner of the motorcycle.

The codes for any keys not submitted during the programming procedure are wiped from memory to ensure that any keys that may have been lost can no longer be used to start the engine.



Notes

If you sell your motorcycle, do not forget to give all keys and the CODE CARD to the new owner.

Ignition switch and steering lock (fig. 16)

The ignition switch is located in front of the top yoke.

The switch has four positions.

- A) **ON**: enables lights and engine operation;
- B) **OFF**: disables lights and engine operation;
- C) **LOCK**: steering locked;
- D) **P**: parking light on and steering locked.







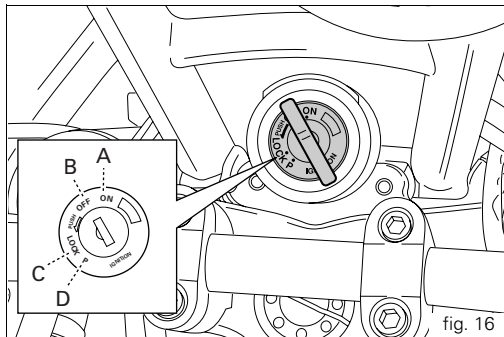



Notes

To move the key to the last two positions, push it in before turning. The key can be removed in positions (B), (C) and (D).



Left-hand handlebar switch (fig. 17)

- 1) Two-position light selector switch:
 - position  = low beam headlight on;
 - position  = high beam headlight on.
- 2) Switch  = 3-position turn signal:
 - centre position = off;
 - position  = left turn;
 - position  = right turn.To cancel the turn signals, press the control switch once it has returned to the central position.
- 3) Button  = warning horn.
- 4) Button  = high beam flasher.
- 5) Button  = hazard warning flashers
Press to switch on the hazard warning indicators.
Press again to switch the hazard warning indicators off.



Notes

When you operate devices (1), (2), (4) and (5) the corresponding indicators lights illuminate on the instrument panel (see page 14).

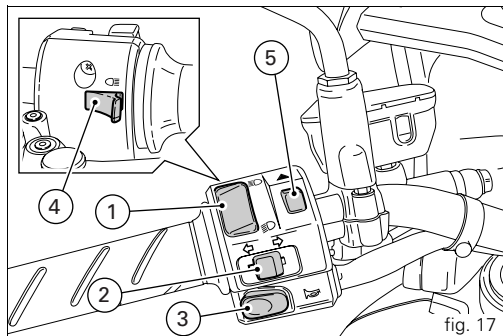

fig. 17

Clutch lever (fig. 18)

The clutch lever (1) is fitted with a span adjuster (2) which serves to alter the distance of the lever from the handlebar. To make the adjustment, keep the lever (1) fully forward and turn the wheel (2) to one of the four preset positions.

Note that:

position n° 1 corresponds to the maximum distance between the lever and grip, while position n° 4 corresponds to the minimum distance.

When the clutch lever (1) is operated, drive from the engine to the gearbox and the rear wheel is disengaged. Correct use of the clutch lever is very important in all riding situations, especially when moving off.



Warning

Set the clutch and brake lever with the motorcycle stopped.



Important

Using the clutch properly will prolong the life of the engine and prevent any damage to components in the transmission.



Notes

It is possible to start the engine with the side stand down and the gearbox in neutral. When starting the motorcycle with a gear engaged, pull the clutch lever (in this case the side stand must be up).

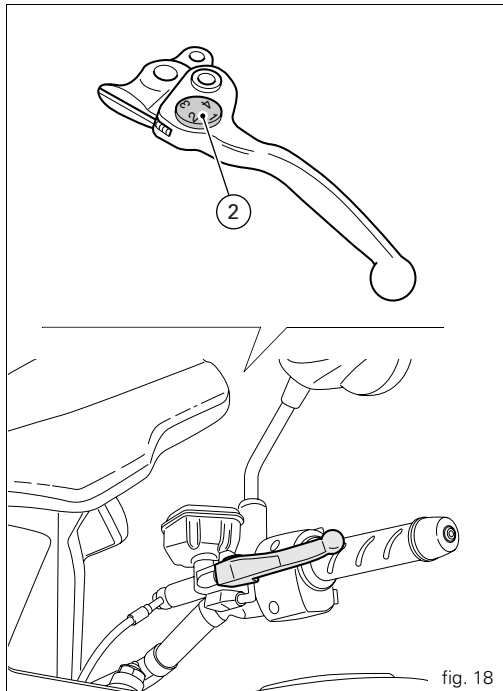





fig. 18

Right-hand handlebar switch (fig. 19)

- 1) **ENGINE STOP** switch, with two positions:
 - position  (**RUN**) = run;
 - position  (**OFF**) = stop engine.



Warning

This switch is mainly intended for use in emergencies when you need to stop the engine quickly. After stopping the engine, return the switch to the  position to start the engine.

- 2) Button  = engine start.

Throttle twistgrip (fig. 19)

The twistgrip (3) on the right handlebar opens the throttles. When released, the twistgrip returns automatically to the initial position (idling speed).

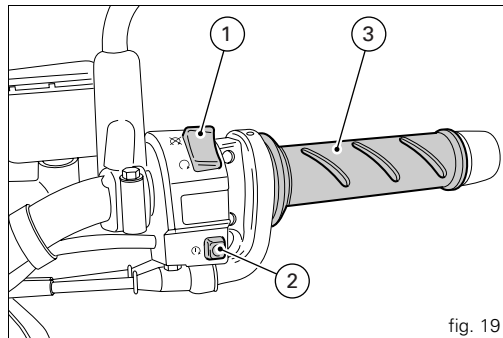

fig. 19

Front brake lever (fig. 20)

Pull the lever (1) towards the twistgrip to operate the front brake. The system is hydraulically assisted and you only need to pull the lever gently.

The brake lever has a wheel (2) for adjusting the distance between lever and twistgrip on the handlebar.

To make the adjustment, keep the lever (1) fully forward and turn the wheel (2) to one of the four preset positions.

Note that:

position n° 1 corresponds to the maximum distance between the lever and grip, while position n° 4 corresponds to the minimum distance.



Warning

Any adjustment of brake levers must be carried out when motorcycle is stationary.

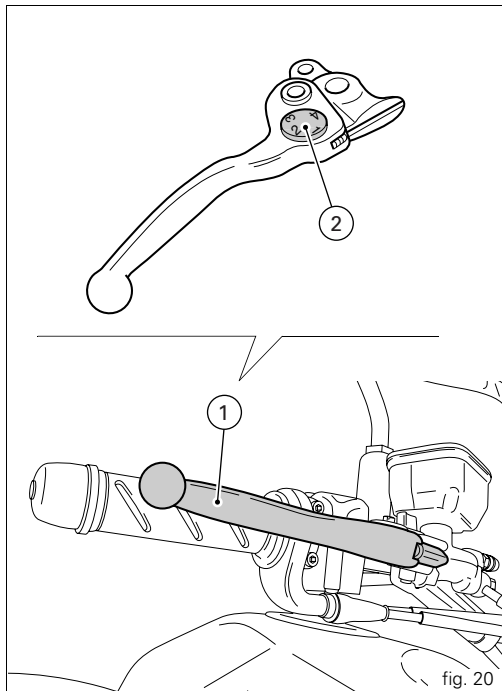

Rear brake pedal (fig. 21)

Push down on the pedal (1) with your foot to operate the rear brake.

The brake system is hydraulic and very little force is required to operate it.

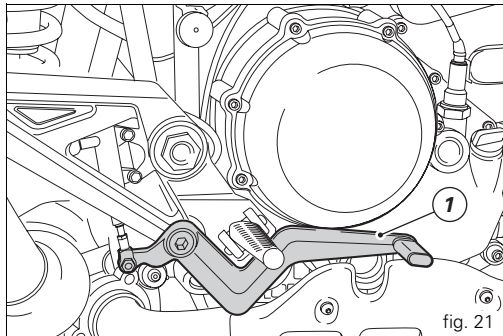

Gearchange pedal (fig. 22)

The gear change pedal is at rest when in centre position N, and automatically returns to the centre position. When in this position, light N (8, fig. 6) on instrument panel comes on.

The pedal can be moved:

down = push down on the pedal to engage 1st gear and to shift down. The N light on the instrument panel goes out.

up = lift the pedal to engage 2nd gear, then 3rd, 4th, 5th and 6th gear.

Each time you move the pedal, you engage the next gear.

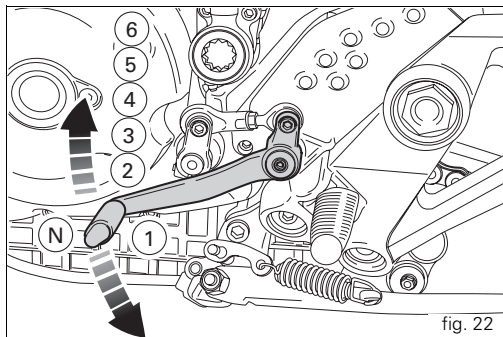

E

Adjusting the position of the gearchange and rear brake pedals

The position of the gearchange and rear brake pedals in relation to the footrests can be adjusted to suit the requirements of the rider.

Proceed as follows to change the pedal position:

E Gearchange pedal (fig. 23)

Use an open ended spanner to hold the rod (1) on the flat (2) and slacken off lock nut (3).

Turn the screw (4) to detach the rod (1) from the gearchange lever.

Turn the rod (1) by means of the flat (2) and move the pedal to the required position.

Tighten the screw (4) to secure the gearchange lever to the rod (1).

Tighten the lock nut (3) against the rod (1).

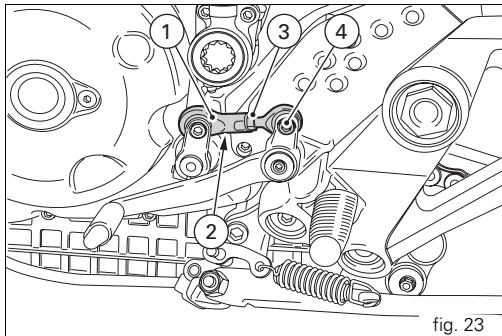

fig. 23

Rear brake pedal (fig. 24)

Loosen the locknut (5).

Turn the pedal travel adjustment bolt (6) until the pedal is in the desired position.

Tighten the locknut (5).

Operate the pedal by hand to check that there is 1.5 to 2 mm of freeplay before the brake bites

If not, adjust the length of the master cylinder pushrod as follows.

Slacken off the locknut (7) on the pushrod.

Screw the pushrod (8) into the clevis (9) to increase the freeplay, or screw it out to reduce it.

Tighten the locknut (7) and recheck the pedal freeplay.

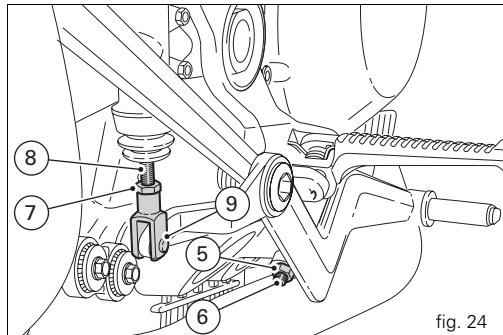

Main components and devices

E

Position on motorcycle (fig. 25)

- 1) Fuel tank filler cap
- 2) Passenger seat lock and helmet holder.
- 3) Document compartment lock.
- 4) Side stand.
- 5) Front fork adjusters.
- 6) Rear shock absorber adjusters.
- 7) Rear view mirrors.
- 8) Silencer and exhaust pipes.
- 9) Catalytic converter.



Warning

The exhaust system might be hot, even after engine is switched off; take special care not to touch exhaust system with any part of your body and do not park the motorcycle next to inflammable material (wood, leaves etc.).

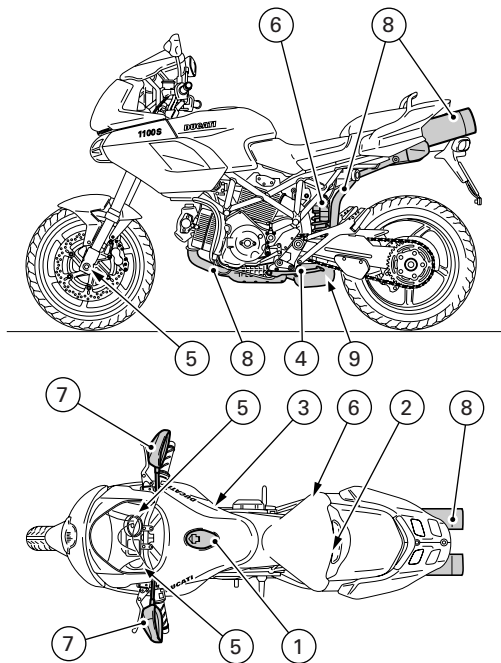

fig. 25

Fuel tank filler cap (fig. 26.1)

Opening

Raise the cover (1) and insert the key into the lock.
Give the key a 1/4 turn clockwise to unlock.
Raise the cap (2, fig. 26.2).

Closing

Close the cap (2) with the key inserted and press it into its seat. Turn the key anticlockwise to the initial position and remove it. Replace the lock cover (1).



Notes

The cap can only be closed with the key inserted.



Warning

Always make sure you have properly closed the fuel filler cap after refuelling (see page 53).

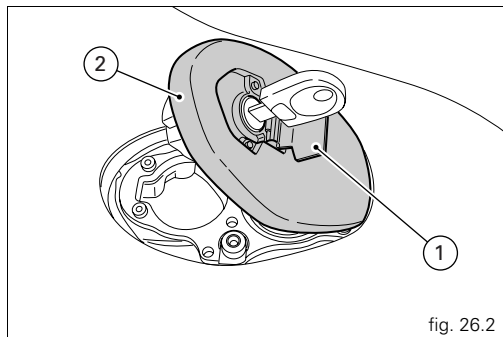
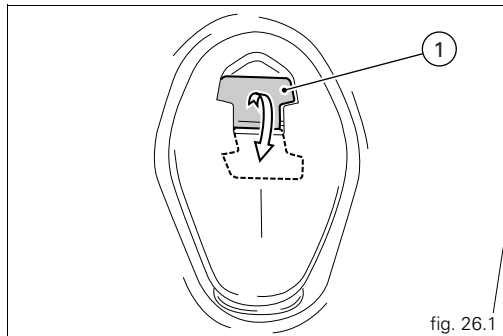

Passenger seat lock and helmet holder

Opening (fig. 27)

Insert the key into the seat lock (1) and turn it clockwise until the seat catch disengages with an audible click. Lift the rear of the seat (2) and slide it backwards off the front mountings.

Closing

Fit the seat over the tank mountings and pull it backwards until it engages. Press down on the rear of the seat until you hear the catch engage with an audible click. Make sure the seat is securely fitted by gently pulling on it in an upward direction.

The hook for the helmet holder cable is located under the passenger seat. Pass the cable (A) through the helmet and fit the ends of the cable into the hook. Leave the helmet hanging on the left side (fig. 28) and refit the seat to secure it.

Warning

This device protects the helmet against theft when the motorcycle is parked. Do not leave the helmet attached in this way when riding the motorcycle, as it can interfere with your movements and cause loss of control of the motorcycle. Hang the helmet cable from the left side of the motorcycle. In any other position the cable will interfere with the seat closure.

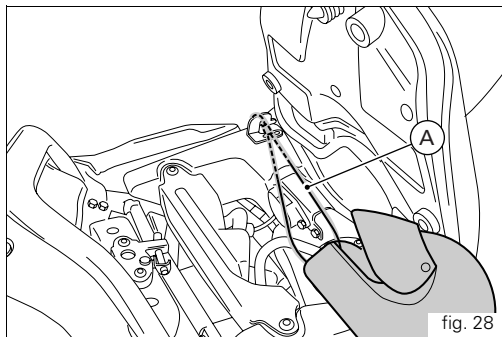
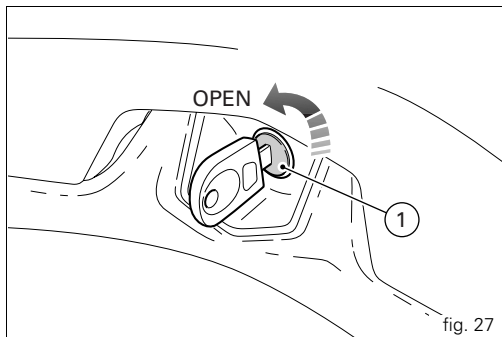

Document compartment lock

To open the cover of the document compartment, insert the key in the lock (1) and turn it anti-clockwise to release the catches (fig. 29.1).

Open the cover (fig. 29.2) of the document compartment to access the user's manual and the toolkit (see page 54).



Important

Do not use this compartment to hold heavy or metal objects that might move about while the motorcycle is in motion, causing loss of stability.

Simply push the cover shut until the locking pin engages to re-close the compartment.

Remove the key.

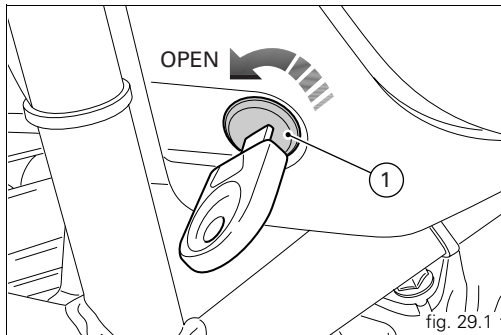

Sidestand (fig. 30)

Important

Before lowering the side stand, make sure that the supporting surface is hard and flat. Do not park on soft ground, gravel or on asphalt softened by the sun etc. or the motorcycle may fall over.

When parking on a slope, always park with the rear wheel on the downhill side.

To lower the sidestand, hold the motorcycle handlebars with both hands and push down on the stand (1) with your foot until it is fully extended. Lean the motorcycle over on its left side until the side stand comes into firm contact with the ground.

Warning

Do not sit on the motorcycle when it is supported on the sidestand.

To move the side stand to its rest position (horizontal position), tilt the motorcycle to the right and, at the same time, lift the thrust arm (1) with your foot.

Check for proper operation of the stand mechanism (two springs, one into the other) and the safety sensor (2) at regular intervals. The sidestand safety circuit is protected by a 3 A fuse located alongside the battery (see page 97).

Notes

You can only start the engine with the sidestand extended if the gearbox is in neutral.

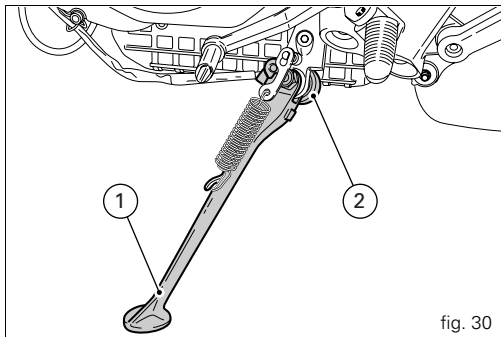

fig. 30

Front fork adjuster

The front fork can be adjusted in rebound, compression and preload.

The settings are adjusted by way of external adjuster screws:

- 1) to adjust rebound damping (fig. 31.1 and fig. 31.2);
- 2) to adjust inner spring preload (fig. 31.1 and fig. 31.2);
- 3) to adjust compression damping (fig. 32.1 and fig. 32.2).

Park the motorcycle in a stable position on its sidestand. Using a 3 mm Allen key (1100 S) or slot-headed screwdriver (1100), turn the adjuster (1) located on the top of each fork leg to adjust the rebound damping. Using a 3 mm Allen key (1100 S) or slot-headed screwdriver (1100), turn the adjuster (3, fig. 32.1 and fig. 32.2) located on the top of each fork leg to adjust the compression damping. As you turn the adjuster (1), you will hear it click. Each click corresponds to a setting. Adjuster (3, fig. 32.1 and fig. 32.2) turns freely to give continuous damping adjustment. The maximum damping is obtained with the adjuster screwed in fully to the "0" position.

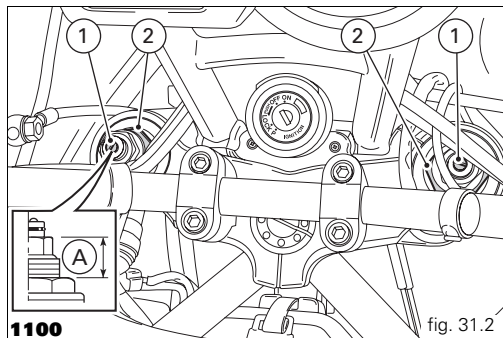
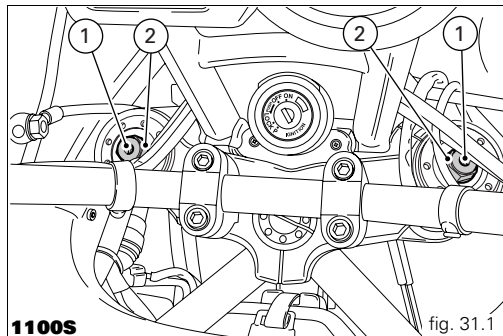

Start from this position and turn the adjuster anti-clockwise while counting the number of clicks, which correspond to position 1, 2 and so forth.

The STANDARD factory settings are as follows:

1100S

compression: 9 clicks;
rebound: 12 clicks.
Spring preload: 10 mm (10 turns, from fully unscrewed,
1 turn = 1 mm).

To change the preload on the inner spring for each fork leg, turn the adjuster with the hex end (2, fig. 31.1) with a 22 mm hex spanner.

1100

compression: 1 and a half turns;
rebound: 2 turns.
Spring preload: 6 mm (6 turns from fully open,
1 turn = 1 mm).

To change the spring preload for each fork leg, turn the adjuster (2, fig. 31.2) with a 22 mm hex wrench. The preload value (A, fig. 31.2) adjustment range is 25 to 10 mm.

 **Important**
Adjust both fork legs to the same setting.

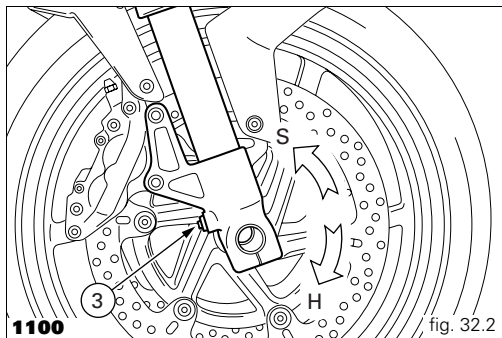
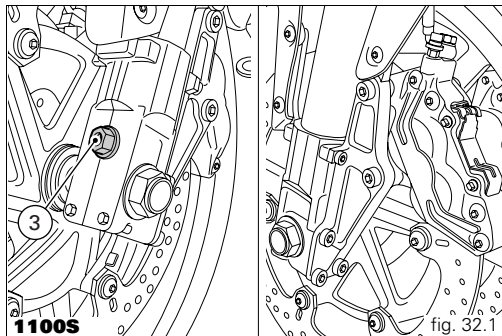

Rear shock absorber adjusters

(fig. 33.1, fig. 33.2, fig. 34.1 and fig. 34.2)

The shock absorber has external adjusters that enable you to adjust the suspension to suit the load on the motorcycle.

The adjuster (1) located on the right-hand side, where the lower end of the shock absorber is attached to the swingarm, controls rebound damping.

The adjuster (2) on the shock absorber reservoir controls compression damping.

Turn the adjusters (1 and 2) clockwise to stiffen the damping or anti-clockwise to soften it.

1100S

STANDARD setting from the fully closed position (clockwise):

- unscrew adjuster (1) by 12 clicks;
- unscrew the adjuster (2) by 10 clicks.

Spring preload: 22 mm.

The preload on the outer spring of the shock absorber can be adjusted by way of the knob (3) located on the right-hand side of the frame; follow the instructions given on the adjuster itself.

The STANDARD setting is obtained when the knob is in the minimum position (LOW).

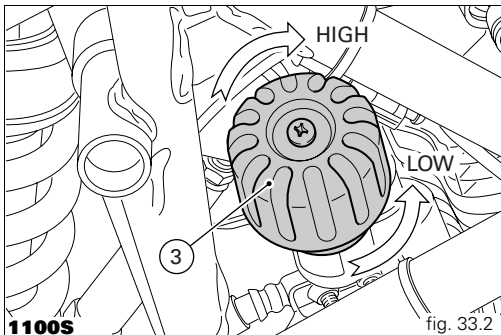
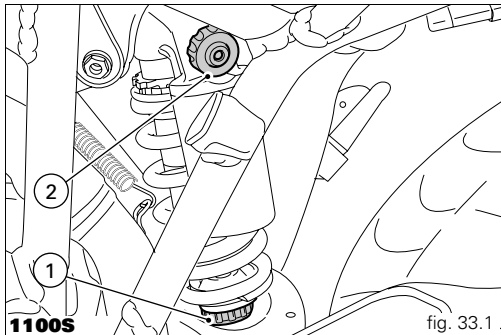

1100

STANDARD rebound damping setting (1): screw the adjuster fully in (clockwise), then screw it out 18 clicks.

STANDARD compression damping setting (2): screw the adjuster all the way in (clockwise), then screw it out by 2 turns.

The preload on the outer spring of the shock absorber can be adjusted by way of the knob (3) located on the right-hand side of the frame; follow the instructions given on the adjuster itself.

The STANDARD setting is obtained when the knob is in the minimum position (LOW).

STANDARD length of "mini-preload" spring: 4 turns (2 mm).

Warning

The shock absorber is filled with gas under pressure and may cause severe damage if taken apart by unskilled persons.

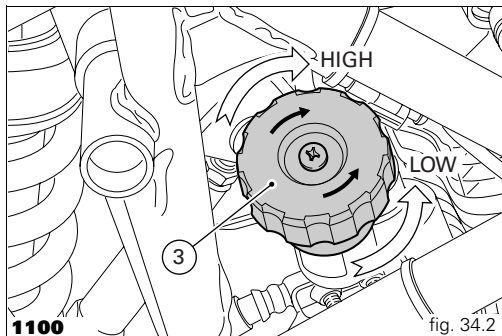
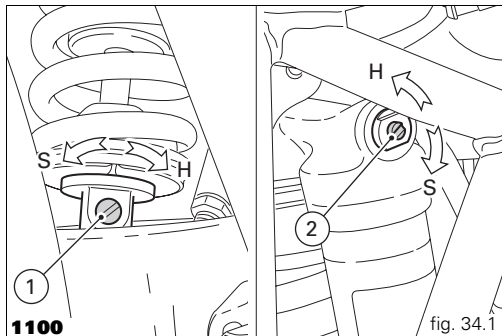

Rear view mirror adjustment

Simply push or pull the outside of the mirrors in the required direction to obtain optimum visibility (fig. 35.1). Tighten the screw at the bottom of the mounting to lock the mirror in the required position (fig. 35.2).



Warning

Never attempt to adjust the position by moving the whole mirror assembly, as this could break it.

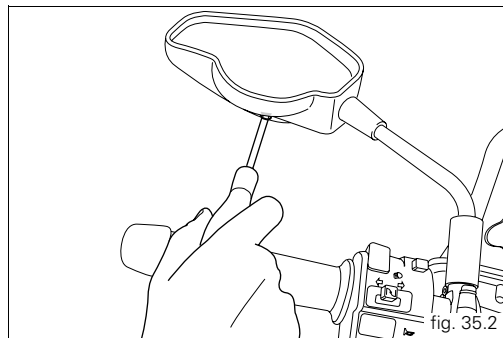
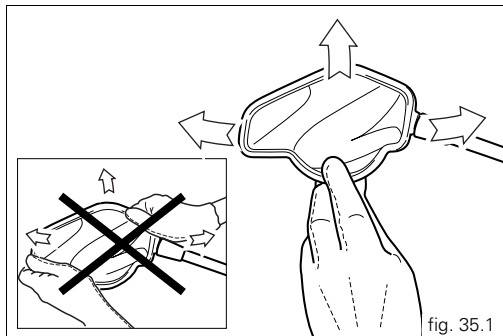

Adjusting the rear ride height

The rear ride height is the result of tests carried out under different riding conditions by our technical staff.

Modifying this parameter is a very critical operation, and can be dangerous if carried out by untrained persons.

Before changing the standard setting, measure the reference value (H, fig. 36.1).

The rider can adjust the rear ride height to suit his/her needs by changing the working position of the rear shock absorber (fig. 36.2).

Increase/decrease the distance between the ends of tie-rod (2) by loosening the nuts (3) of the ball joints (1) and turning the flats (A).

Once the tie-rod length is adjusted correctly, tighten the nuts (3) to 25 Nm.

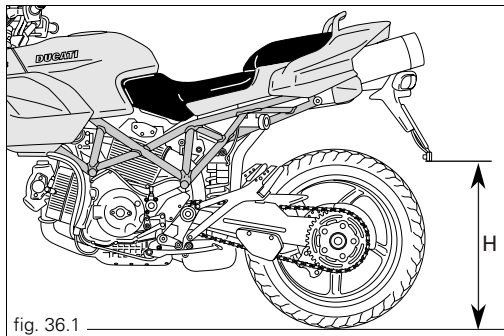

Notes

Note that the lower nut (3) has a left-hand thread.



Warning

The length of the tie-rod (2) between the centres of the two ball joints (1) is 255 mm.

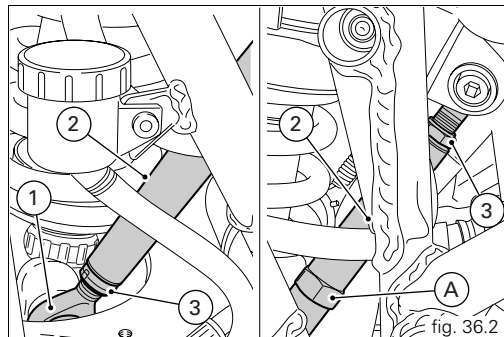

The maximum distance that the UNIBALL end fitting (A) can be unscrewed from the tie-rod body is 5 threads, or 7.5 mm (B).

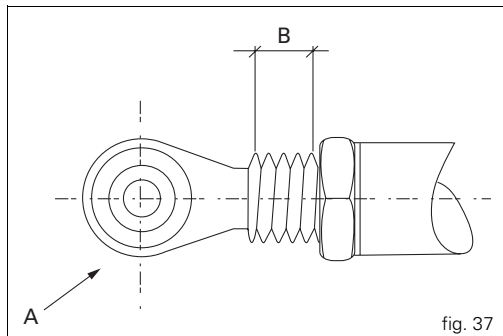

E

Riding the motorcycle

E

Running-in precautions

Max. engine speed (fig. 38)

Rpm limits to be observed during the running-in period and in normal use:

- 1) Up to 1000 km;
- 2) From 1000 to 2500 km.

Up to 1000 km

During the first 1000 km, keep an eye on the tachometer.

The revs should never exceed:

5500 to 6000 rpm.

During the first hours of riding, it is advisable to continuously vary the load on the engine and the rpm, though still keeping within the above limits.

For this reason, roads with numerous bends and hilly areas are ideal for running in the engine, brakes and suspension.

For the first 100 km, use the brakes gently. Do not brake violently or keep brake applied for too long. This will enable a correct break-in of friction material on brake pads against brake discs.

To allow all the mechanical moving parts in the motorcycle to adapt to one another, and to avoid shortening the life of the main engine components, it is advisable to avoid sudden acceleration and running the engine at high rpm for too long, especially uphill.

It is also advisable to check the drive chain frequently and ensure that it is lubricated as required.

From 1000 to 2500 km

At this point, you can ask for more power from the engine, being careful, however, never to exceed:

7000 rpm.

Important

Throughout the running-in period, be careful to stick to the recommended maintenance schedule and periodic service intervals indicated in the warranty booklet. Failure to follow these instructions releases Ducati Motor Holding S.p.A. from any liability whatsoever for any engine damage or shorter engine life.

Keeping to the running-in recommendations will ensure longer engine life and reduce the need for overhauls and re-tuning.

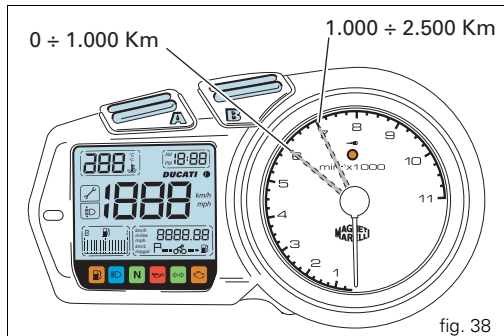

E

Pre-ride checks



Warning

Failure to carry out these checks before starting may result in damage to the motorcycle and injury to the rider.

Before starting, check the following points:

Fuel level in the tank

Check the fuel level in the tank. Re-fuel if necessary (page 53).

Engine oil level

Check the oil level in the sump through the sight glass. Top up if necessary (page 80).

Brake and clutch fluid

Check fluid level in the related reservoirs (page 60).

Tyre condition

Check the pressure and condition of the tyres (page 78).

Controls

Operate the brake, clutch, throttle and gear change controls (levers, pedals and twistgrip) to check that they function correctly.

Lights and indicators

Make sure the lights, indicators and horn work properly. Replace any burnt-out bulbs (page 68).

Key locks

Check that the fuel filler cap (page 35) and the seat are locked (page 36).

Sidestand

Make sure the sidestand operates smoothly and is in the correct position (page 38).



Warning

In case of malfunctioning, do not start the motorcycle and call a DUCATI Dealer or Authorized Workshop.

Starting the engine



Warning

Before starting the engine, familiarise yourself with the controls that you will use when riding (see page 11)

- 1) Turn the ignition switch to **ON** (fig. 39). Check that both the green light **N** (8, fig. 6) and the red light  (7, fig. 6) on the instrument panel come on.



Important

The oil pressure warning light should go out a few seconds after the engine has started (page 14).



Notes

The engine can be started with the sidestand down and the gearbox in neutral. When starting the engine with a gear engaged, pull in the clutch lever (in this case the sidestand must be in the raised position).

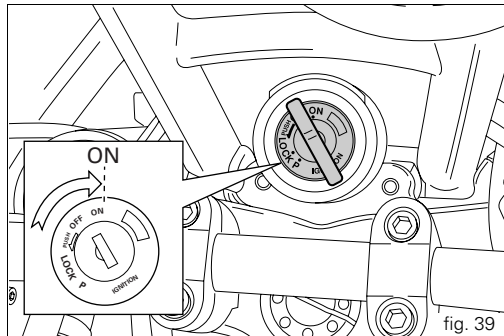

E

- 2) Check that the stop switch (1, fig. 40) is positioned to **○ (RUN)**, then press the starter button (2).

This model has servo-assisted starting.

To use the servo-assisted starting feature, press the start button (2) and release it immediately.

When you press the button (2) the starter motor operates automatically for a maximum time determined by the engine temperature.

The system disengages the starter motor as soon as the engine starts.

If the engine fails to start, wait at least 2 seconds before pressing the start button (2) again.

Allow the engine to start on its own, without turning the throttle twistgrip.

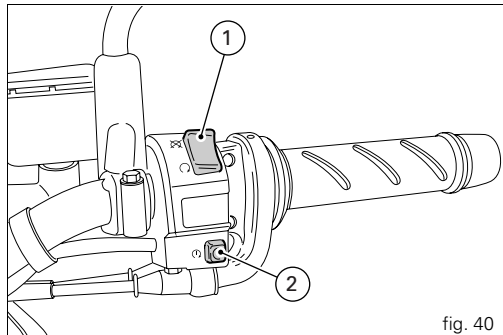

fig. 40



Notes

If the battery is flat, the system automatically disables operation of the starter motor.



Important

Do not rev the engine when cold. Allow some time for the oil to warm up and reach all points that need lubricating.

Moving off

- 1) Disengage the clutch by squeezing the control lever.
- 2) Push down the gearchange lever firmly with the tip of your foot to engage first gear.
- 3) Raise the engine revs by turning the throttle twistgrip while gradually releasing the clutch lever. The motorcycle will start moving.
- 4) Release the clutch lever completely and accelerate.
- 5) To change up a gear, close the throttle to reduce the engine revs, disengage the clutch, lift the gearchange lever and release the clutch lever. To change down, proceed as follows: release the twistgrip, pull the clutch lever, increase engine speed for a moment to allow the gears to synchronize, shift down and release the clutch. Use the controls intelligently and promptly: when riding uphill do not hesitate to shift down as soon as the motorcycle tends to slow down, so you will avoid lugging the engine and stressing the motorcycle abnormally.



Important

Avoid sudden acceleration, as this may lead to misfiring and transmission snatching. The clutch lever should not be pulled longer than necessary after gear is engaged, otherwise friction parts may overheat and wear out.

Braking

Slow down in time, change down to use the engine brake, then apply both brakes. Pull the clutch lever before stopping the motorcycle, to avoid sudden engine stop.



Warning

Use both brake lever and pedal for effective braking. Using only one of the brakes will give you less braking power.

Never use the brake controls harshly or suddenly as you may lock the wheels and lose control of the motorcycle.

When riding in the rain or on slippery surfaces, braking capacity is significantly reduced. Always use the brakes very gently and carefully when riding under these conditions.

Any sudden manoeuvres may lead to loss of control.

When riding down long, steep downhill slopes, change down to use engine braking. Apply the brakes intermittently for brief periods only. Keeping the brakes applied continuously causes the friction material to overheat and dangerously reduces braking effectiveness. Under-inflated or over-inflated tyres reduce braking efficiency and may adversely affect safe riding and road-holding on bends.

Stopping the motorcycle

Reduce speed, shift down and release the throttle twistgrip. Change down to engage first gear and then neutral. Apply the brakes and bring the motorcycle to a complete stop. Switch the engine off by turning the key to **OFF** (page 26).

E Parking

Stop and park the motorcycle on the side stand (see page 38).

To prevent theft, turn the handlebar fully left and turn the ignition key to the **LOCK** position.

If you park in a garage or other facility, make sure that there is proper ventilation and that the motorcycle is not near a source of heat.

If necessary, you can leave the side lights on by turning the key to position **P**.



Important

Do not leave the key at **P** for long periods or the battery will run down. Never leave the motorcycle unattended with the ignition key inserted.



Warning

The exhaust system might be hot, even after engine is switched off; take special care not to touch exhaust system with any part of your body and do not park the motorcycle next to inflammable material (wood, leaves etc.).



Warning

Using padlocks or other locks designed to prevent movement of the motorcycle (such as brake disc locks, rear sprocket locks, and so on) is very dangerous, and may impair motorcycle operation and the safety of rider and passenger.

Refuelling (fig. 41)

Do not overfill the tank when refuelling. The fuel level should always be below the rim of the filler recess.



Warning

Use fuel with low lead content and an original octane number of 95 minimum (see table "Fluids and lubricants" on page 89).

Check that no fuel is trapped in the filler cap recess.

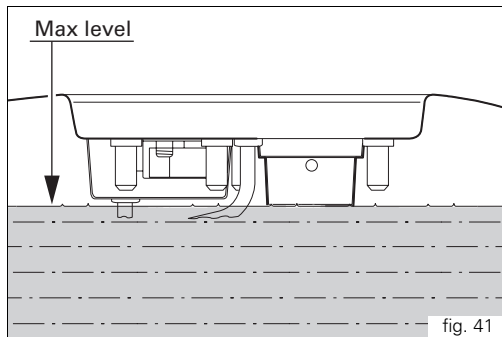

E

Toolkit and accessories (fig. 42)

A compartment in the right-hand fairing, accessible by opening the access cover (see page 37), houses:

- the use and maintenance manual;
- the helmet fastening cable;
- the toolkit including (fig. 43):
 - spark plug wrench;
 - Tommy bar for spark plug wrench;
 - double-bit screwdriver.



fig. 42

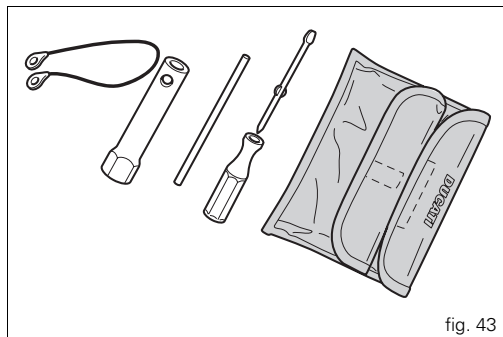

fig. 43

Main Use and Maintenance Operations

Removing the fairing panels

Some parts of the motorcycle fairing have to be removed for certain maintenance or repair operations.



Warning

If parts that have been removed are not refitted correctly they may become loose suddenly while riding and cause you to lose control of your motorcycle.



Important

On refitting the headlamp fairing, always refit the nylon washers in correspondence with the retaining screws to avoid damaging the painted parts and the Plexiglas windshield.

Movable nose fairing

Unscrew the four screws (1) securing the movable headlight fairing to the brackets with the seal (2). Remove the movable headlight fairing complete with the windshield (fig. 44).

To replace the windshield, use the special torx wrench to unscrew the screws (3) and nylon washers (4), while holding the rubber coated nuts (5) in position from the inside the fairing (fig. 45).

When fitting the new windshield, tighten the screws (2) starting with the central screw.

Make sure that the seals (2) are correctly fitted to the brackets, then fit the movable headlight fairing and secure it with the screws (1).

Tighten the screws (1).

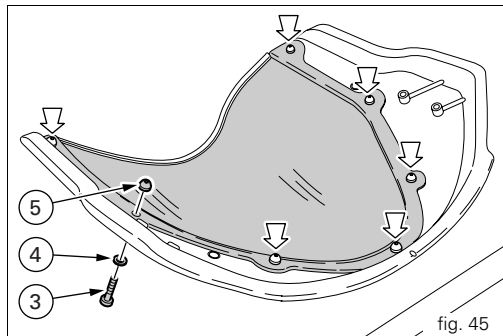
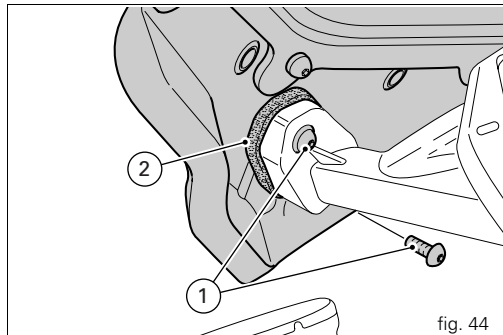

Fixed nose fairing

Unscrew the six screws (1) securing the inside panel to both sides of the fixed headlight fairing and lift the fairing off (fig. 46).



Notes

When removing the shroud take care not to damage the paintwork of the fairing.

Unscrew the six screws (2) securing the fixed headlight fairing to the headlight bracket (fig. 47).
Remove the fixed fairing.

When refitting, tighten the four central screws first, then the two side screws.

Fit the inside panel to the fixed headlight fairing and align the holes.

Tighten the screws (1), taking care not to over-tighten and damage the fixed fairing inserts.

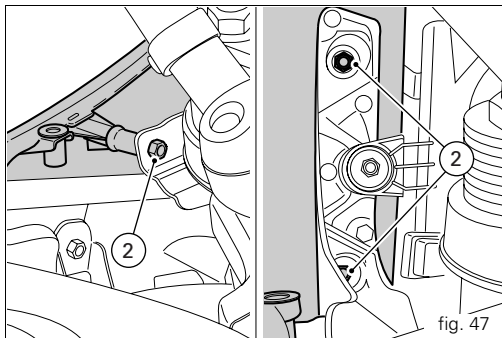
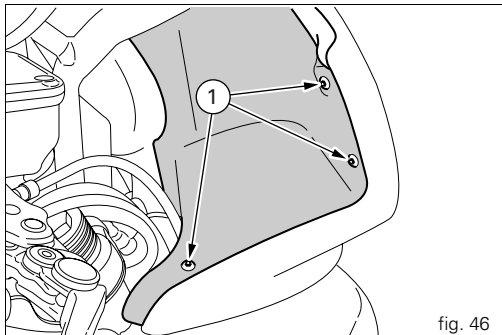

Left half fairing

Starting on the left, from inside the fairing, turn the quick release fastener (1) 1/4 of a turn anti-clockwise to release the front of the left half fairing (fig. 48).

To release the rear of the left half fairing, pull the stop (2) all the way out at the frame bracket: to facilitate this operation, push the side fairing in from the outside at the stop (fig. 49).

Remove the left half fairing from the mounting pins on the fuel tank.

E

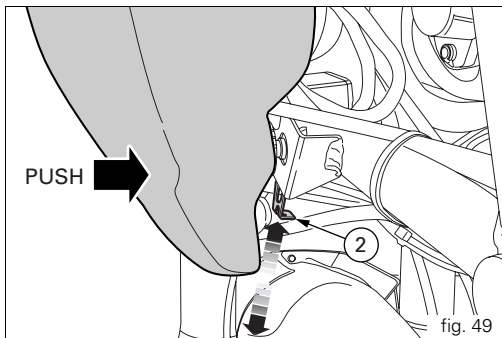
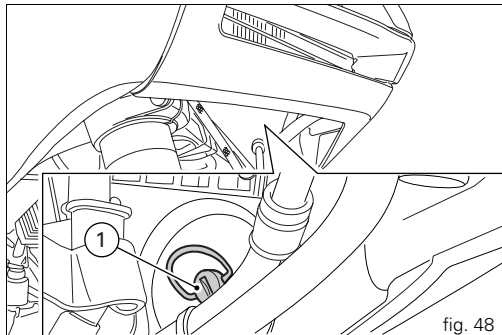

Before refitting the half fairing, make sure that the grommets (3) and seal (4) are correctly fitted over the pin (5) on the inside of the half fairing (fig. 50).

Fit the left side fairing, starting from the rear, engaging the tank pins in the grommets (fig. 51).

Push on the side fairing at the pin (5) to engage the stop (2) over the end of the pin.

Engage the front quick release fastener (1), pushing it in and turning it 1/4 of a turn clockwise.

Panniers

The motorcycle has provision for fitting side panniers.

The pannier kit is available from the Ducati parts service.

As well as all the parts necessary for fitting, the kit also contains an instruction booklet.

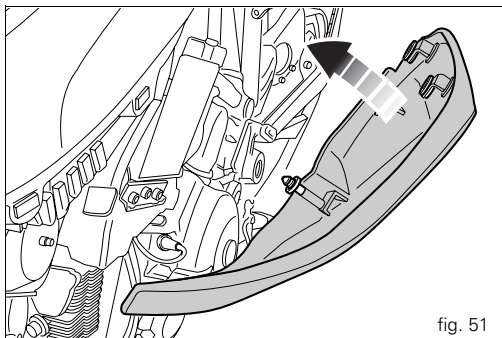
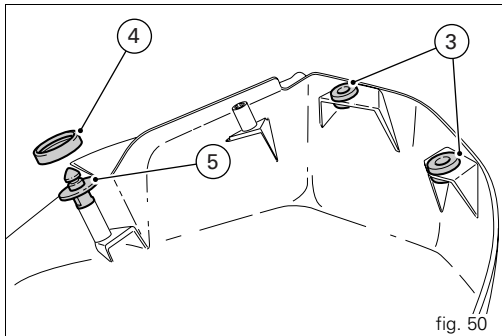

Checking the brake and clutch fluid level

The level must not fall below the **MIN** mark on the corresponding reservoirs (fig. 52 and fig. 53).

If level drops below the limit, air can get into the circuit and make the system ineffective.

Brake and clutch fluid must be topped up and changed at the intervals specified in the routine maintenance table (see Warranty Card) by a Ducati Dealer or Authorized Workshop.

Important

It is recommended that all brake and clutch hoses be renewed every four years.

Brake system

If there is excessive play on the brake lever or pedal, and brake pads are still in good condition, contact a Ducati Dealer or Authorized Workshop to have the system inspected and air bled from the circuit.

Warning

Brake and clutch fluid is harmful to paintwork and plastic parts, so do not allow it to come into contact with them. Hydraulic oil is corrosive and can cause damage and injuries. Never mix oils of different qualities. Check that the seals are in good condition.

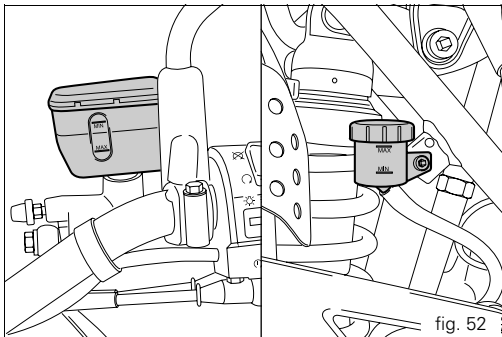

Clutch system (fig. 53)

If the control lever has excessive play and the transmission snatches or jams when engaging a gear, then there is probably air in the circuit. Contact a Ducati Dealer or Authorized Workshop, who will check the system and bleed the circuit.



Warning

The level of clutch fluid tends to increase in the reservoir as the friction material on the clutch plates wears out. Do not exceed the specified level (3 mm above the minimum level).

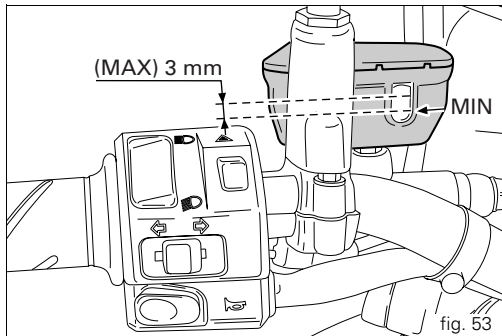

E

Checking the brake pads for wear (fig. 54)

The brake pads are marked with wear indicators so that they can be checked without removing them from the calipers. If the grooves in the friction material are still visible, the pad is still in good condition.

The rear brake pads must be replaced when about 1 mm of friction lining (fig. 55) is still visible through the opening in the calipers.

Important

Have the brake pads replaced at a Ducati Dealer or Authorized Workshop.

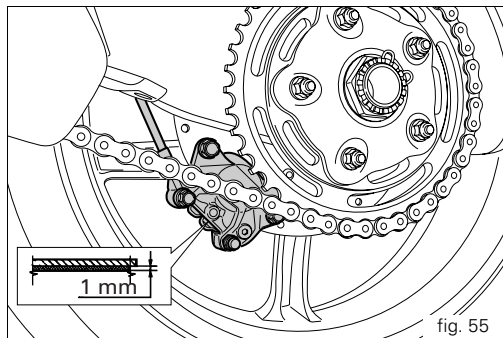
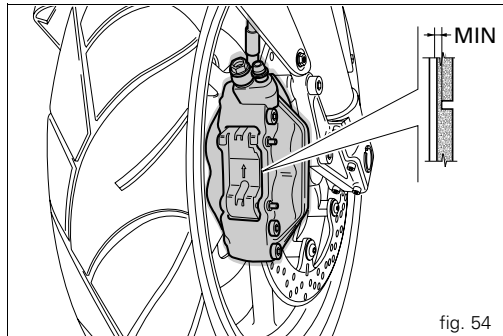

Lubricating cables and joints

The condition of the outer throttle cables should be checked at regular intervals. The outer cables should show no signs of kinking or cracking. Operate the controls to make sure the inner cables slide smoothly inside the outer cables: if you feel any friction or catching, have the cable replaced by a Ducati Dealer or Authorized Service Centre.

To prevent failure open the throttle control by unscrewing the two fastening screws (1, fig. 56) then grease the cable ends and the pulley with SHELL Advance Grease or Retinax LX2.



Warning

Close the twistgrip housing carefully, inserting the cable in the race.

Refit the housing and tighten the screws (1) to 6 Nm.

To ensure smooth operation of the sidestand pivot, remove any dirt and apply SHELL Alvania R3 to all points subject to friction (1, fig. 57).

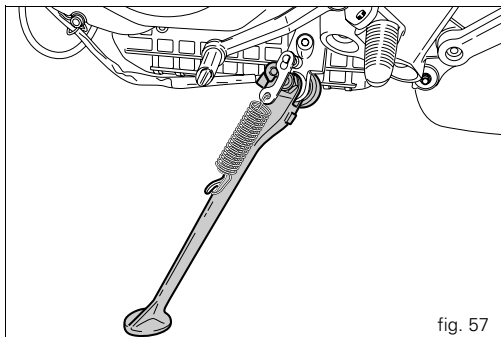
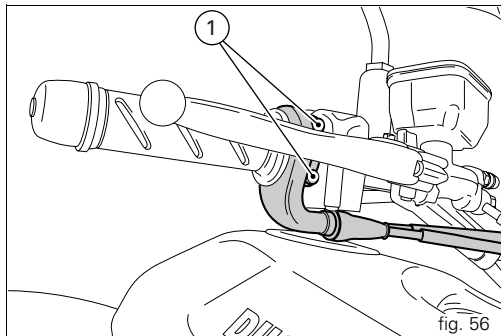

Adjustment of the throttle cable free play

The throttle twistgrip should have free play of 1.5 to 2.0 mm (fig. 58) (measured in terms of twistgrip rotation) in all steering positions.

If this is not the case, adjust the cable by means of the adjusters (1) on the throttle body (fig. 59).

E



Important

Refer the adjustment of throttle control play to a Dealer or Authorized Workshop.

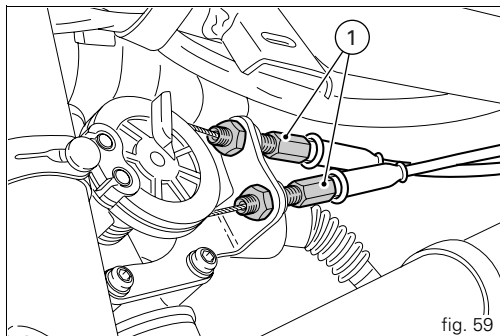
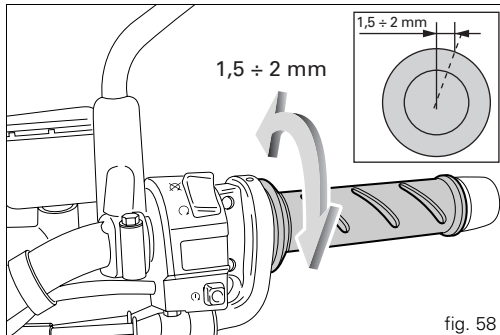

Charging the battery (fig. 60)

Before charging the battery, it is best to remove it from the motorcycle.

Remove the left half fairing (see page 58). Always disconnect the black negative terminal (-) first, and then the red positive terminal (+).

Unscrew the two screws (1) securing the battery brackets and remove the battery from the battery compartment.

Warning

The battery produces explosive gases: keep it away from heat sources and flames.

Charge the battery in a well-ventilated area.

Connect the red battery charger lead to the positive (+) terminal on the battery, and the black lead to the negative (-) terminal.

Important

Always connect up the battery before switching the battery charger on: failure to do so can result in sparking at the battery terminals, which could ignite the gases inside the cells.

Always connect the red positive terminal (+) first.

Reinstall the battery on its support and secure the brackets with the screws (1). Connect the terminals. Use some grease on the fastening screws to improve conductivity.

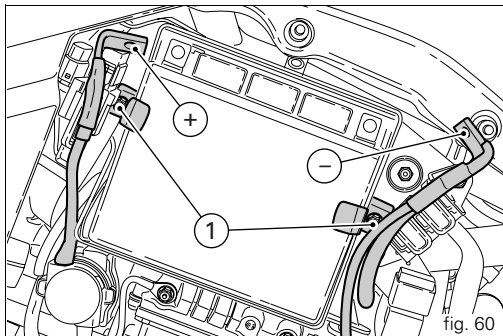

fig. 60

Warning

Keep the battery out of the reach of children.

Charge the battery at 0.9 A for 5 to 10 hours.

Checking the chain tension (fig. 61)

Slowly move the motorcycle to determine the position at which the chain is most taut.

Rest the motorcycle on its sidestand. At the foremost point of the side chain guard, check the distance between the swingarm and the middle of the links in the bottom run of the chain. The distance must be between 38 and 42 mm, as shown on the label on the swingarm. If it is not, adjust the chain tension accordingly.



Important

Have the chain tensioned at a Ducati Dealer or Authorized Workshop.



Warning

Correct tightening of the swingarm bolts (1, fig. 62) is essential to rider and passenger safety.



Important

An incorrectly tensioned chain will cause the rapid wear of transmission parts.

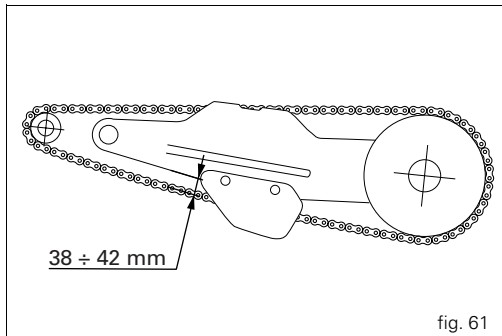

fig. 61

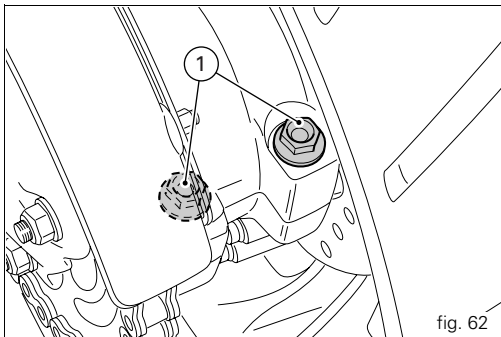

fig. 62

Lubricating the drive chain

The chain fitted on your motorcycle has O-rings that keep dirt out of and lubricant inside the sliding parts.

So as not to damage these seals when cleaning the chain, use special solvents and avoid aggressive washing with high-pressure steam cleaners.

After cleaning, blow the chain dry with compressed air or wipe with an absorbent material, then lubricate each link with SHELL Advance Chain or Advance Teflon Chain.

Important

Using non-specific lubricants may cause severe damage to the chain and the front and rear sprocket.

Changing the high and low beam headlight bulbs

Before replacing a burnt-out bulb, make sure that the new one matches the voltage and wattage specifications in the "Electrical System" paragraph on page 96. Always check that the new bulb works before refitting removed parts. Figure fig. 63 shows the position of the low beam (LO), high beam (HI) and parking light (1) bulbs.

To access the headlight bulbs, release the top and bottom springs (2) under the instrument panel at the side of the fixed headlight fairing (fig. 64), and open the shell (3).



Notes

For clarity, the headlight is shown removed from the vehicle.

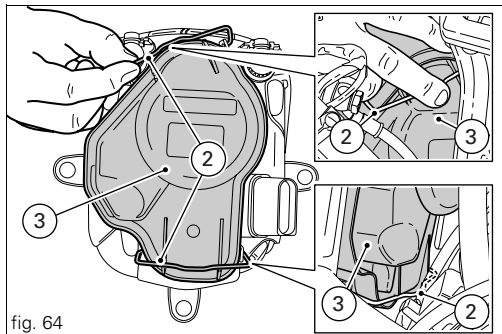
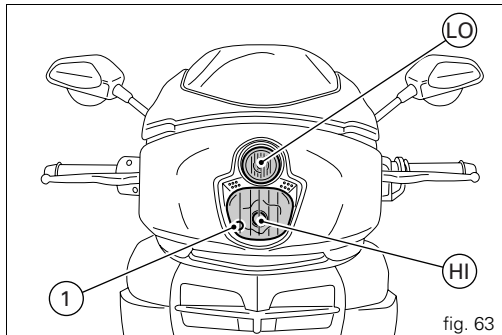

Low beam headlight (top bulb)

Disconnect the wiring connectors (4) from the bulb. Press then squeeze the ends of the spring (5) to detach it from the bulb holder (fig. 65). Lift the spring (5).

Remove the old bulb (6) and fit the new one, taking care not to touch the glass (fig. 66).



Notes

Be careful to hold the new bulb at the base only. Never touch the transparent body with your fingers or it will blacken resulting in reduced bulb brilliancy.

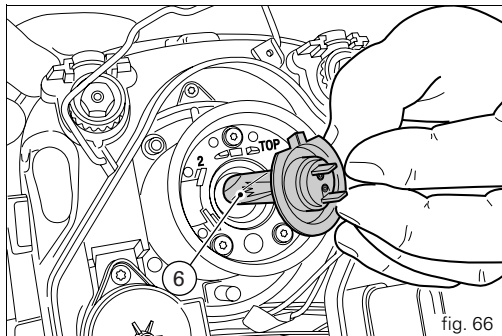
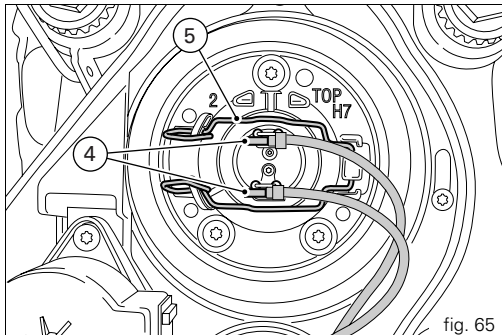



Notes for the USA version:

To remove the low beam headlight bulb (7), detach the connector (A) from the wiring, then turn the bulb counter-clockwise to remove it (fig. 67). Replace with a bulb of equal rating. When fitting the new bulb, turn it clockwise to lock it in the holder.

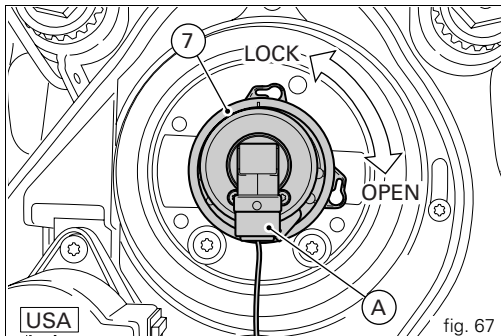

fig. 67

High beam headlight (bottom bulb)

Disconnect the wiring connector (8) from the high beam bulb (fig. 68)

Press down then squeeze the ends of the spring (9) to detach it from the bulb holder.

Lift the spring (9).

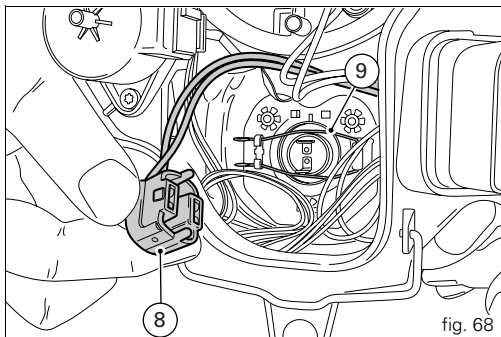

fig. 68

Remove the old bulb (10) and fit the new one, taking care not to touch the glass (fig. 69).

Parking light

Disconnect the wiring connectors (11) from the terminals (fig. 70).

Remove the side light bulb (12) from its holder and fit a new one of the same type.

Refitting the bulbs

After changing the bulbs, reconnect the wiring connectors to the light terminals. Reposition the headlight cover in its location, taking care to line up the profiles, and secure it to the headlight body by tightening the retaining clips.



Notes

It is possible to invert the wires to the bulb terminals.

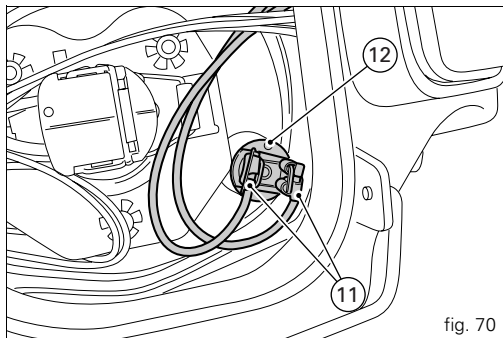
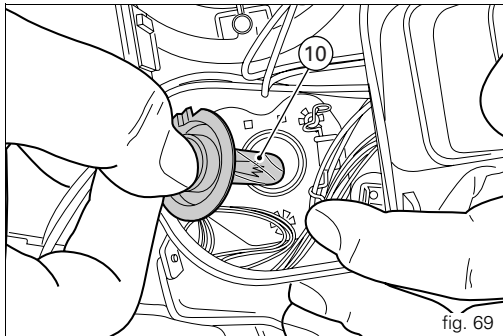

Changing the front turn indicator bulbs

The front turn signals are integrated in the rear view mirrors. To replace the bulb, unscrew the screw (1) and remove the lens (2) of the indicator from the mirror (fig. 71).

The bulb (3) is of the bayonet-type: press and twist anti-clockwise to remove. Replace the burned out bulb with a new one of the same rating. Press the bulb in and twist clockwise until it clicks into place (fig. 72).

Refit the lens (2) into the slot in the indicator body so that their profiles coincide.

Secure the lens with the screw (1).

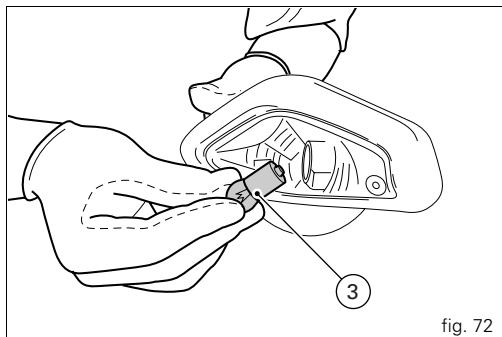
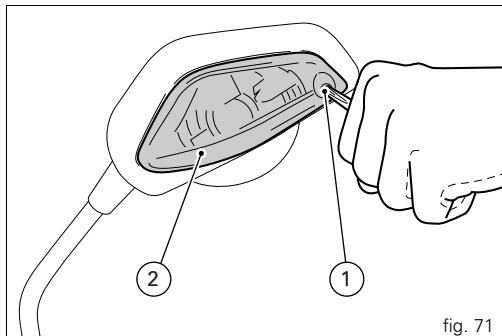

Changing the rear turn indicator bulbs

To change the rear turn indicator bulbs, rotate the indicator body (1) by a quarter of a turn so that the lens is facing upwards, and extract it from indicator support (fig. 73).

The bulb (2, fig. 74) is of the bayonet type: push it in and turn it anti-clockwise to remove it. Push in the new bulb and turn it clockwise until it clicks into place. Refit the indicator body (1) to its support and rotate it by a quarter of a turn.

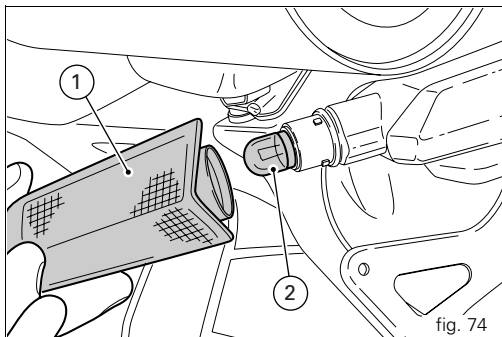
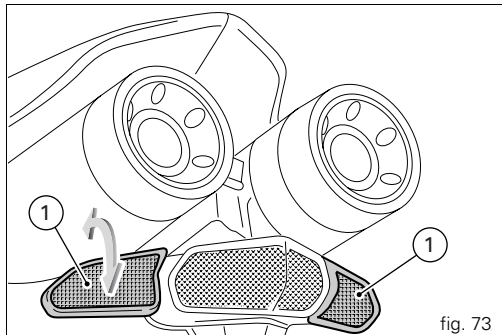

Changing the number plate light and brake light bulbs

Unscrew the two screws (1) securing the rear light mounting to the number plate holder on the inside of the holder.

Unscrew the screw (2) and slightly withdraw the rear light support (fig. 75).

Disconnect the connector (A) of the rear wiring harness and remove the rear light mounting (fig. 76).

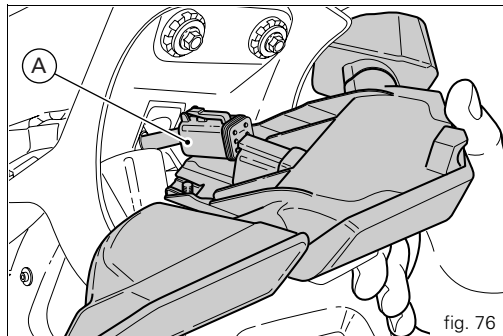
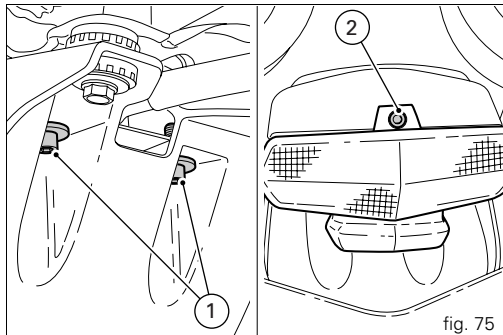

Unscrew the two self-tapping screws (3) securing the shell (4) and the number plate light lens.
Remove the shell and the lens and change the number plate light bulb (5) (fig. 77).
To change the brake light bulb, proceed as above and also remove the brake light lens (6) from its support.
Push and twist the bulb (7) anti-clockwise to remove it (fig. 78).
When refitting the lens (6) make sure that the tabs (B) engage the slots in the support correctly.

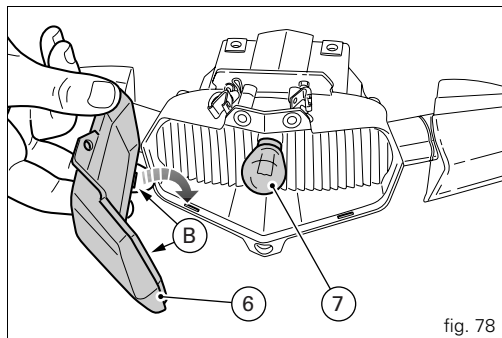
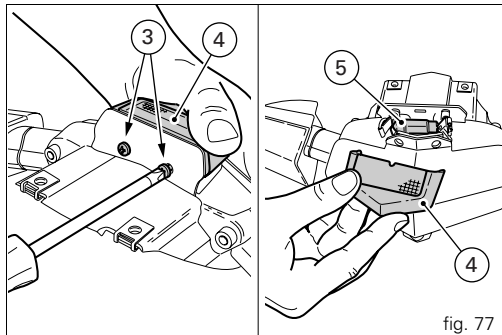

Headlight aim (fig. 79)

To check the headlight aim, place the motorcycle upright with the tyres inflated to the correct pressure and one person sitting astride the motorcycle. The motorcycle should be perfectly vertical, with its longitudinal axis at right angles to a wall or screen at a distance of 10 metres. Draw a horizontal line at the height of the centre of the headlamp and a vertical one at the longitudinal axis of the motorcycle. If possible, perform this check in conditions of low ambient light.

Switch on the low beam headlight.

The height of the light spot (measured at the upper limit between dark and lighted-up area) should not exceed $\frac{9}{10}$ th of the height from ground of headlamp centre.

Notes

This is the procedure specified by Italian regulations for checking the maximum height of the light beam. Owners in other countries should adapt this procedure to the regulations in force in the country where the motorcycle is used.

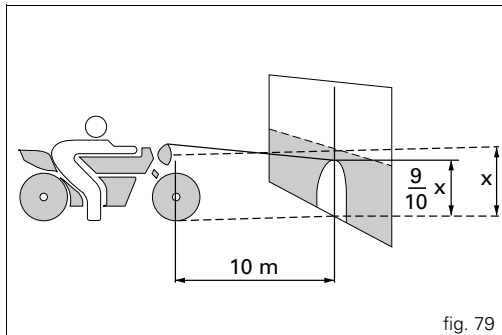

fig. 79

Headlight vertical adjustment (fig. 80)

The vertical alignment of the headlamp can be adjusted manually by turning the screw (1).
Horizontal alignment can be adjusted by turning screw (2).



Notes

To access the headlight adjuster screws, remove the fixed headlight fairing.



Important

Screws (1) and (2) have no travel limit.

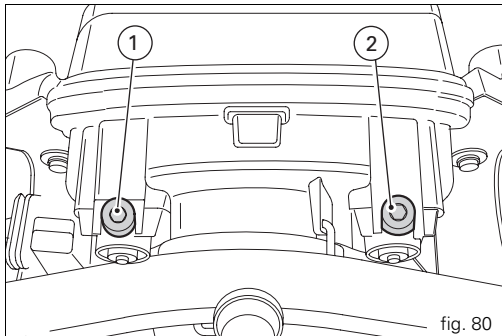

E

Tubeless tyres

Front tyre pressure:

220 Kpa (2.2 bar -32.3 psi)

Rear tyre pressure:

240 Kpa (2.4 bar – 35.2 psi)

Tyre pressures are affected by temperature and altitude variations, so you are advised to check and adjust them whenever you are riding in areas with wide variations in temperature or altitude.

Important

Check and adjust the pressures with the tyres cold. To prevent distortion of the front wheel rim, increase tyre pressure by 0.2 to 0.3 bar when riding on bumpy roads.

Tyre repair or replacement (Tubeless)

In the event of a minor puncture, tubeless tyres will take a long time to deflate, as they tend to keep air inside. If you find that one of the tyres is slightly deflated, check the tyre for slow punctures.



Warning

Punctured tyres must be renewed.

Replace with tyres of the original brand and type.

Be sure to tighten the valve dust caps securely to prevent leaks while riding. Never use tube type tyres. Failure to heed this warning may lead to sudden tyre bursting and to serious danger to rider.

After replacing a tyre, the wheel must be balanced.



Important

Do not remove or alter the position of the wheel balancing weights.



Notes

If tyres need changing, contact a Ducati Dealer or Authorized Service Centre to make sure wheels are removed and refitted correctly.

Minimum tread depth

Measure the tread depth (S, fig. 81) at the point where the tread is most worn.

It should not be less than 2 mm, and in any case not less than the legal limit.

Important

Visually inspect the tyres at regular intervals for cracks and cuts, especially on the side walls, and bulges or large stains that indicate internal damage. Replace them if badly damaged.

Remove any stones or other foreign bodies stuck in the tread.

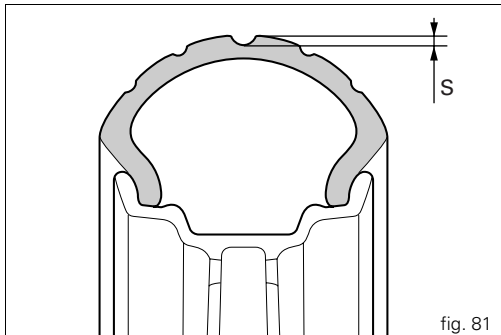

Checking the engine oil level (fig. 82)

Check the engine oil level through the sight glass (1) on the clutch cover on the right hand side of the engine. When checking oil level, the motorcycle should be upright and the engine cold. Oil level should be between the marks next to the sight glass. Top up oil level with SHELL Advance Ultra 4, if low. Undo the filler plug (2) and top up to correct level. Replace the filler cap.

Important

Engine oil and oil filters must be changed by a Ducati Dealer or Authorized Workshop at regular intervals, as specified in the routine maintenance chart (see Warranty Card).

Oil viscosity SAE 15W-50

The other viscosity degrees indicated in the table can be used if the local average temperature is within the limits specified for that oil viscosity.

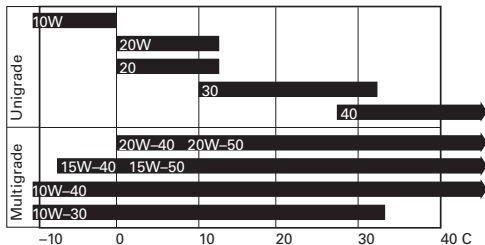
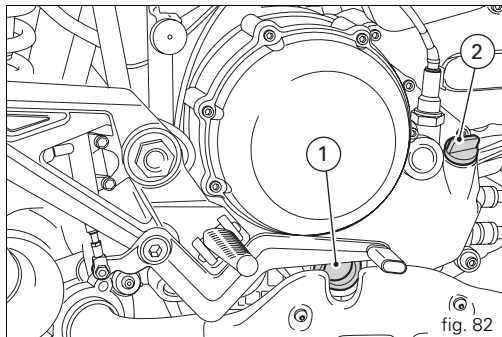

Cleaning and renewing the spark plugs

(fig. 83)

Spark plugs are an important part of the engine and should be checked at regular intervals.

Spark plug condition provides a good measure of engine condition.

Have the spark plugs inspected or replaced at a Ducati Dealer or Authorized Workshop. Firstly, they will check the colour of the ceramic insulator of the central electrode: an even brown colour is a sign that the engine is in good running order.

Secondly, they will check the central electrode for wear and measure electrode gap. The electrode gap should be:

0.6 to 0.7 mm.

Important

A gap outside the specified limits will adversely affect engine performance and may lead to difficult starting or erratic idling.

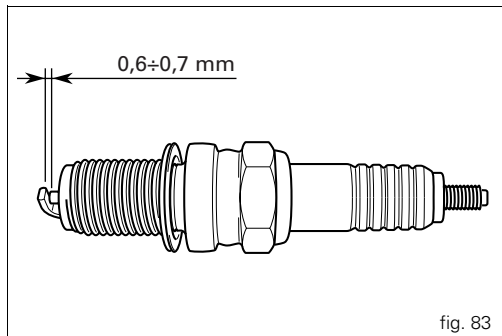

fig. 83

General cleaning

To preserve the original shine on metal surfaces and paintwork, wash and clean your motorcycle at regular intervals depending on the type of use and according to the particular road conditions. Use specific products, where possible biodegradable. Avoid aggressive detergents or solvents.

E

Important

Do not wash your motorcycle immediately after use, as marks can form due to evaporation of the water on hot surfaces. Never clean the motorcycle using hot or high-pressure water jets. Cleaning the motorcycle with water cleaners may lead to seizure or severe failure of front fork, wheel hub assembly, electric system, front fork seals, air inlets or exhaust silencers and adversely affect the operation of motorcycle safety features.

If parts of the engine are unusually dirty or greasy, use a degreasing agent, avoiding contact with transmission components (chain, front and rear sprockets, etc.). Rinse with warm water and dry all surfaces with chamois leather.



Warning

There may be loss of braking efficiency immediately after washing the motorcycle. Never grease or lubricate the brake discs as this would cause loss of braking effectiveness. Clean the discs with an oil-free solvent.

Storing the motorcycle

If the motorcycle is to be left unused for a long period, it is advisable to carry out the following operations first:

clean the motorcycle;

drain the fuel from fuel tank;

pour a few drops of engine oil into the cylinders through the spark plug seats, then crank the engine by hand a few times to form a protective film of oil on the cylinder inner walls;

place the motorcycle on the paddock stand;

disconnect and remove the battery.

If the motorcycle has been left unused for more than a month, the battery should be checked and re-charged if necessary.

Protect the motorcycle with the special cover available from Ducati Performance that will not damage the paintwork or retain moisture.

Important notes

The legislation in some countries (France, Germany, Great Britain, Switzerland etc.) sets certain noise and pollution standards.

Periodically carry out the required checks and renew parts as necessary, using Ducati original spare parts, in compliance with the regulations in the country concerned.

Maintenance

E

Programmed maintenance plan: operations to be carried out by the dealer

List of operations with frequency (distance or time interval*)	km x1000	1	12	24	36	48	60
	miles x1000	0.6	7.5	15	22.5	30	37.5
	Months	6	12	24	36	48	60
Change the engine oil		●	●	●	●	●	●
Change the engine oil filter		●	●	●	●	●	●
Clean the engine oil pick-up filter					●		
Check the engine oil pressure				●		●	
Check/adjust the valve clearances (1)			●	●	●	●	●
Check the tension of the timing belts (1)			●		●		●
Renew the timing belts				●		●	
Check and clean the spark plugs. Renew if necessary				●		●	
Check and clean the air filter (1)			●		●		●
Change the air filter				●		●	
Check throttle body synchronisation and idle speed setting (1)			●	●	●	●	●

List of operations with frequency (distance or time interval*)	km x1000	1	12	24	36	48	60
	miles x1000	0.6	7.5	15	22.5	30	37.5
	Months	6	12	24	36	48	60
Check the brake and clutch fluid levels		●	●	●	●	●	●
Change the clutch and brake fluid					●		
Check and adjust the brake and clutch control cables			●	●	●	●	●
Check/lubricate the throttle/choke cables			●	●	●	●	●
Check tyre pressure and wear		●	●	●	●	●	●
Check the brake pads. Renew if necessary		●	●	●	●	●	●
Check the steering head bearings				●		●	
Check the drive chain tension, alignment and lubrication		●	●	●	●	●	●
Check the clutch disc pack. Renew if necessary (1)			●	●	●	●	●
Check the rear wheel cush drive				●		●	
Check the wheel hub bearings				●		●	
Check the indicators and lighting			●	●	●	●	●
Check tightness of nuts and bolts securing the engine to the frame			●	●	●	●	●
Check the sidestand			●	●	●	●	●
Check tightness of the front wheel axle nut			●	●	●	●	●
Check tightness of the rear wheel axle nut			●	●	●	●	●
Check the external fuel hoses			●	●	●	●	●
Change the front fork oil					●		
Check the forks and rear shock absorber for oil leaks			●	●	●	●	●

List of operations with frequency (distance or time interval*)	km x1000	1	12	24	36	48	60
	miles x1000	0.6	7.5	15	22.5	30	37.5
	Months	6	12	24	36	48	60
Check the front sprocket retaining bolts			●	●	●	●	●
General lubrication and greasing			●	●	●	●	●
Check and recharge the battery			●	●	●	●	●
Road test the motorcycle		●	●	●	●	●	●
General cleaning			●	●	●	●	●

* Service operation to be carried out in accordance with the specified distance or time intervals (km, miles or months), whichever occurs first.

(1) Operation to be carried out only at the specified distance intervals.

Programmed maintenance plan: operations to be carried out by the dealer

List of operations with frequency (distance or time interval*)	km x1000	1
	miles x1000	0.6
	Months	6
Checking the engine oil level		●
Check the brake and clutch fluid levels		●
Check tyre pressure and wear		●
Check the drive chain tension and lubrication		●
Check the brake pads. If necessary, contact your dealer to renew pads		●

*** Service operation to be carried out in accordance with the specified distance or time intervals (km, miles or months), whichever occurs first.**

Technical data

E

Overall dimensions (mm) (fig. 84)

Weights

Dry weight in riding order without fuel:

196 kg.

Fully laden:

410 kg.



Warning

Failure to observe weight limits could result in poor handling and impair the performance of your motorcycle, and could result in loss of control.

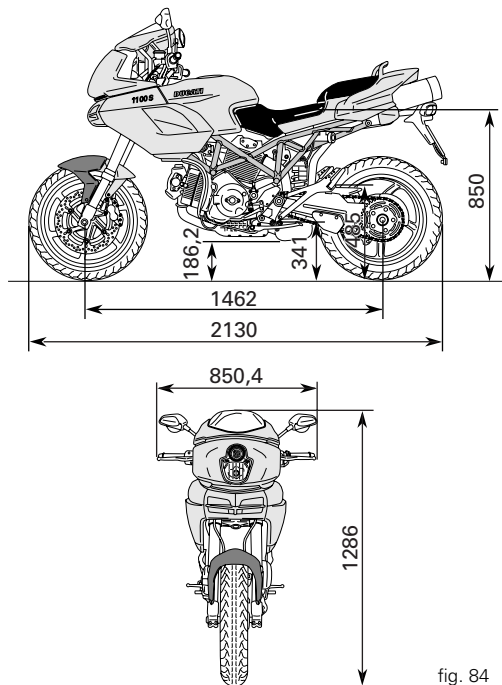

fig. 84

Fluids and lubricants	Type	dm³(litres)
Fuel tank, including a reserve of 3 dm ³ (litres)	Unleaded fuel with 95 fuel octane rating (at least)	20
Lubrication circuit	SHELL - Advance Ultra 4	3.8
Front/rear brake and clutch circuits	Special hydraulic system fluid SHELL Advance Brake Dot 4	—
Protection for electrical contacts	SHELL - Advance Contact Cleaner spray for electric systems	—
Front fork	SHELL - Advance Fork 7.5 or Donax TA	160 mm (per leg) from top of sleeve (1100S) 550 per fork leg, oil level height (1100)



Important

Do not use additives in fuel or lubricants.

Engine

90 degree twin cylinder four stroke, 1100 cc, Desmodromic valve gear, electronic fuel injection, air cooled.

Bore (mm):

98

Stroke (mm):

71.5

Total displacement cm³:

1079

Compression ratio:

10.5 ± 0.5:1

Max power at crankshaft (95/1/EC):

70 kW -95 HP at 7750 rpm

Max torque at crankshaft (95/1/EC):

102.9 Nm -10.5 kg at 4750 rpm

Max rotation speed, rpm

8500



Important

Do not exceed the specified rpm limits in any running conditions.

Timing system

Desmodromic with two valves per cylinder, operated by four rocker arms (two opening rockers and two closing rockers) and one overhead camshaft. It is operated by the crankshaft through spur gears, belt rollers and toothed belts.

Desmodromic timing system (fig. 85)

- 1) Opening (or upper) rocker arm;
- 2) opening shim;
- 3) half rings;
- 4) closing (or lower) shim;
- 5) return spring for closing rocker;
- 6) closing (or lower) rocker arm;
- 7) camshaft;
- 8) valve.

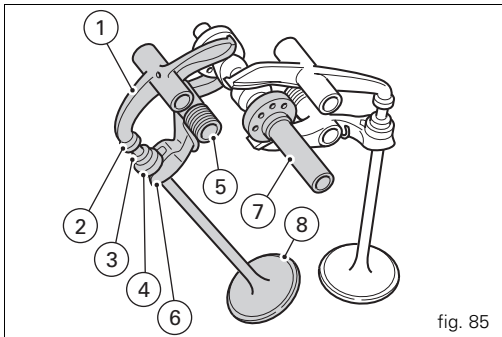

fig. 85

Performance data

Maximum speed in any gear should be reached only after the correct running-in period with the motorcycle properly serviced at the recommended intervals.

Spark plugs

Ignition is provided by two spark plugs per cylinder. This solution ensures more complete combustion and greater power, especially at medium revs.

Make:
CHAMPION

Type:
RA6 HC
alternative

Make:
NGK
Type:
DCPR8E.

Fuel system

MARELLI indirect electronic injection
Throttle body diameter:
45 mm
Injectors per cylinder: 1
Holes per injector: 1
Fuel supply: 95-98 RON.

Exhaust system

Equipped with catalytic converter in compliance with Euro 3 emission regulations.

Transmission

The clutch drum and plates are made entirely from special aluminium alloy.

Wet clutch controlled by lever on left-hand side of the handlebar.

Transmission from engine to gearbox main shaft via spur gears.

Final drive ratio:

32/59

6-speed gearbox with constant mesh gears, gear change pedal on left side of motorcycle.

Final drive ratio:

15/42

Total gear ratios:

1st 15/37

2nd 17/30

3rd 20/27

4th 22/24

5th 24/23

6th 28/24

Drive transmitted from gearbox to rear wheel via chain:

Make:

RK

Type:

525 GXW

Dimensions:

5/8"x5/16".

Number of links:

106.



Important

The above gear ratios are approved and should not be modified under any circumstances.

However, if you wish to tune up your motorcycle for competitive trials, you may refer to Ducati Motor Holding S.p.A. who will be glad to provide information about the special ratios available. Contact a Ducati Dealer or Authorized Workshop.



Warning

For replacement of the rear sprocket, contact a Ducati Dealer or Authorized Workshop. Incorrect replacement of this component could seriously endanger rider and passenger safety and cause irreparable damage to the motorcycle.

Brakes

Front

With double semi-floating drilled disc.

Flange material:

steel.

Braking surface material:

steel.

Disc diameter:

320 mm.

Hydraulically operated by a control lever on right handlebar.

Braking surface:

88 cm².

Make of brake callipers:

BREMBO

Type:

30/34 - 4 pistons.

Friction material:

FERIT I/D 450FP

Master cylinder type:

PSC16 with built-in reservoir.

Rear

With fixed drilled steel disc.

Flange material:

steel.

Braking surface material:

steel.

Disc diameter:

245 mm.

Hydraulically operated by pedal on R.H. side.

Braking surface:

32 cm².

Make:

BREMBO

Type:

34 -2 pistons

Friction material:

FERIT I/D 450 FF

Master cylinder type:

PS 11B.



Warning

The brake fluid used in the brake system is corrosive. In the event of accidental contact with eyes or skin, wash the affected area with copious amounts of running water.

Frame

High-strength tubular steel trellis frame.

Steering angle (on each side):

35°

Steering geometry is as follows:

Steering head rake:

24°

Trail:

92 mm.

Wheels

Front

Six spoke, light alloy front wheel.

Dimensions:

MT3.50x17".

Rear

Light alloy, five spokes.

Dimensions:

MT5.50x17".

The front wheel is mounted on a removable axle. The rear wheel is cantilever mounted on the hub at the rear of the single-sided swingarm.

Tyres

Front

Radial tubeless tyre

Size:

120/70-ZR17

Rear

Radial tubeless tyre

Size:

180/55-ZR17

Suspension

Front

Hydraulic upside-down fork provided with outer adjuster for rebound, compression, and preload (for inner springs of fork legs).

Stanchion diameter:

43 mm.

Travel along leg axis:

165 mm.

Rear

Progressive linkage with a rocker arm connecting the frame and upper pivot point of the shock absorber.

The shock absorber is equipped for adjustment of rebound and compression damping and spring preload.

At the bottom pivot point it is connected to a light-alloy single-sided swingarm. The swingarm hinges on a pivot shaft that passes through the frame and engine.

This system gives the motorcycle excellent stability.

Shock absorber travel:

145 mm.

Available colours

1100S

Ducati anniversary red code no. 473.101 (PPG);
Transparent, 228.880 (PPG);
red frame with black wheels.

Gloss black, code 248.514 (PPG);
Transparent, 228.880 (PPG);
black frame with black wheels.

Pearl white primer part no. 490.019 (PPG) + enamel part no. *0040 (PPG);
Clear coat part no. 228.880 (PPG);
Racing Gray frame and black wheel rims.

1100

Ducati anniversary red code no. 473.101 (PPG);
Transparent, 228.880 (PPG);
black frame and rims.

Electrical system

The main components of the electrical system are:

Front headlight with two vertically arranged halogen lamps, consisting of the following:

low beam unit **H7 (12V-55W)**;

high beam unit **H7 (12V-55W)** for EU and UK - **H9 (12V-65W)** for USA;

parking light **12V-6W**.

Electrical controls on handlebars.

Turn signals, bulbs **12V-10W**.

Horn

Brake light switches

Sealed battery 12V-10 Ah.

Alternator 12V-520W.

Electronic voltage regulator (rectifier), protected by a **30 A** fuse near the battery.

Starter motor, Denso, **12V-0.7 kW**.

Tail light with double filament bulb **12V-5/21W** for brake and parking light; number plate light **12V-5W**.



Notes

To replace the bulbs, see "Replacing bulbs" on page 68.

Fuses

The main fuse box (1, fig. 86) is located under the left side fairing (see page 58). Remove the protective cover to access the fuses.

In addition to the fuses in the main fuse box, other fuses are located alongside the battery.

Two fuses (2, fig. 87) located at the right hand side of the battery protect the relay of the injection system and engine control unit.

Fuse (3) protects the electronic regulator and fuse (4) protects the sidestand position sensor circuit.

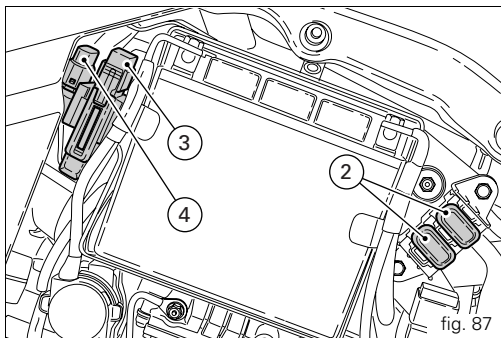
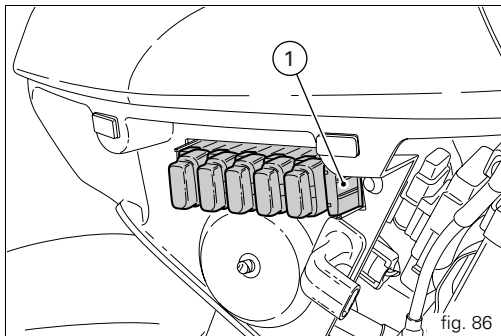

Remove the protective cap (A, fig. 88) to expose the fuses.

A blown fuse is identified by a broken inner filament (5, fig. 89).



Important

Switch the ignition key to OFF before replacing the fuse to avoid possible short circuits.



Warning

Never use a fuse with a rating other than that specified. Failure to observe this rule may damage the electric system or even cause fire.

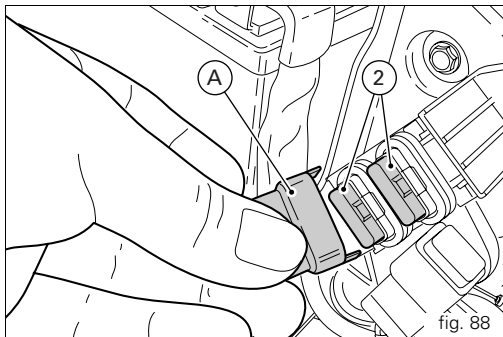

fig. 88

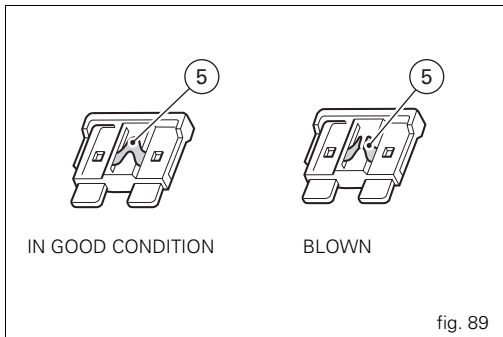

fig. 89

Key to the electrical system/injection system diagram

- 1) Right-hand handlebar switch
- 2) Key switch
- 3) Fusebox
- 4) Fuses
- 5) Starter motor
- 6) Starter contactor
- 7) Battery
- 8) Master fuse
- 9) Regulator
- 10) Alternator
- 11) Rear right-turn signal
- 12) Tail light
- 13) Rear left-turn signal
- 14) Number plate light
- 15) Fuel tank
- 16) Horizontal cylinder spark plug
- 17) Vertical cylinder spark plug
- 18) Injection relay
- 19) Self-diagnosis connection
- 20) Vertical cylinder coil
- 21) Horizontal cylinder coil
- 22) Horizontal cylinder spark plug
- 23) Vertical cylinder spark plug
- 24) Horizontal cylinder injector
- 25) Vertical cylinder injector
- 26) Throttle position sensor
- 27) Rpm/timing sensor
- 28) Oil temperature sensor
- 29) Speed sensor
- 30) Sidestand switch
- 31) Neutral switch
- 32) Oil pressure switch
- 33) Rear brake light switch
- 34) Stepper motor
- 35) Ignition/injection unit
- 36) Clutch switch
- 37) Front brake light switch
- 38) Instrument panel oil temperature sensor
- 39) Left-hand handlebar switch
- 40) Immobilizer antenna
- 41) Air temperature sensor
- 42) Instrument panel
- 43) Lights relay
- 44) Front left-turn signal
- 45) Headlight
- 46) Front right-turn signal
- 47) Horn
- 48) Heated handgrip wiring connector

Wire colour coding

B Blue
W White
V Violet
Bk Black
Y Yellow
R Red
Lb Light blue
Gr Grey
G Green
Bn Brown
O Orange
P Pink

Key to the fusebox

Pos.	Device	Val.
a	Key on	10 A
b	Lights	15 A
c	Horn, brake light, passing	15 A
d	Instrument panel	5 A
e	Hand grip heating	5 A
f	Injection	20 A
g	Engine ECU power	3 A
h	Master	30 A



Notes

The electrical system wiring diagram is at the end of this manual.

For United States of America version Only

Reporting of safety defects

If you believe that your vehicle has a defect which could cause a crash or could cause injury or death, you should immediately inform the National Highway Traffic Safety Administration (NHTSA) in addition to notifying Ducati North America. If NHTSA receives similar complaints, it may open an investigation, and if it finds that a safety defect exists in a group of vehicles, it may order a recall and remedy campaign. However, NHTSA cannot become involved in individual problems between you, your dealer, or Ducati North America. To contact NHTSA, you may either call the Auto Safety Hotline toll-free at 1-800-424-9393 (or 366-0123 in Washington, D.C. area) or write to: NHTSA, U.S. Department of Transportation, 400 7th street sw, (NSA-11) Washington, D.C. 20590. You can also obtain other information about motor vehicle safety from the Hotline.

Safety warnings

Traffic Rules vary from jurisdiction to jurisdiction. Know the regulations in your jurisdiction before riding this motorcycle.



Warning

This motorcycle is designed and intended for use on streets and other smooth, paved areas only. Do not use this motorcycle on unpaved surfaces. Such use could lead to upset or other accident.

Noise emission warranty

Ducati Motor S.p.A. warrants that this exhaust system, at the time of sale, meets all applicable U.S. EPA Federal noise standards. This warranty extends to the first person who buys this exhaust system for purposes other than resale, and to all subsequent buyers. Warranty claims should be directed to: Ducati North America, Inc., 10443 Bandle Drive, Cupertino, California, 95014
Tel: 001.408.253.0499 - Fax: 001.408.253.4099

Noise and exhaust emission control system information

Source of Emissions

The combustion process produces carbon monoxide and hydrocarbons. Control of hydrocarbons is very important because under certain conditions, they react to form photochemical smog when subjected to sunlight. Carbon monoxide does not react in the same way, but is toxic. Ducati utilizes lean carburetor settings and other systems to reduce carbon monoxide and hydrocarbons.

Exhaust Emission Control System

The Exhaust Emission Control System is composed of lean carburetor settings, and no adjustments should be made except idle speed adjustments with the throttle stop screw. The Exhaust Emission Control System is separate from the crankcase emission control system.

Crankcase Emission Control System

The engine is equipped with a closed crankcase system to prevent discharging crankcase emissions into the atmosphere. Blow-by gas is returned to the combustion chamber through the air cleaner and the throttle body.

Evaporative Emission Control System

California motorcycles are equipped with an evaporative emission control system which consists of a charcoal canister and associated piping. This system prevents the escape of fuel vapors from the throttle body and fuel tank.

Tampering warning

Tampering with Noise Control System Prohibited. Federal Law prohibits the following acts or causing thereof:

- (1) the removal or rendering inoperative by any person, other than for purposes of maintenance, repair, or replacement, of any device or element of design incorporated into any new vehicle for the purpose of noise control prior to its sale or delivery to the ultimate purchaser or while it is in use; or
- (2) the use of the vehicle after such device or element of design has been removed or rendered inoperative by any person.

Among those acts presumed to constitute tampering are the acts listed below:

- (1) Removal of, or puncturing the muffler, baffles, header pipes or any other component which conducts exhaust gases.
 - (2) Removal or puncturing of any part of the intake system.
 - (3) Lack of proper maintenance.
 - (4) Replacing any moving part of the vehicle, or parts of the exhaust or intake system, with parts other than those specified by the manufacturer.
- This product should be checked for repair or replacement if the motorcycle noise has increased significantly through use. Otherwise, the owner may become subject to penalties under state and local ordinances.

Problems that may affect motorcycle emissions

If you are aware of any of the following symptoms, have the vehicle inspected and repaired by your local Ducati dealer.

Symptoms:

- Hard starting or stalling after starting.
- Rough idle.
- Misfiring or backfiring during acceleration.
- After-burning (backfiring).
- Poor performance (driveability) and poor economy.

Riding safety

The points given below are applicable for every day motorcycle use and should be carefully observed for safe and effective vehicle operation.

A motorcycle does not provide the impact protection of an automobile, so defensive riding in addition to wearing protective apparel is extremely important.

Do not let protective apparel give you a false sense of security.

Before changing lanes, look over your shoulder to make sure the way is clear. Do not rely solely on the rear view mirror; you may misjudge a vehicle's distance and speed, or you may not see it at all.

When going up steep slopes, shift to a lower gear so that there is plenty of power to spare rather than overloading the engine.

When applying the brakes, use both the front and rear brakes. Applying only one brake for sudden braking may cause the motorcycle to skid and lose control.

When going down long slopes, control vehicle speed by closing the throttle. Use the front and rear brakes for auxiliary braking.

Riding at the proper rate of speed and avoiding unnecessarily fast acceleration are important not only for safety and low fuel consumption but also for long vehicle life and quieter operation.

When riding in wet conditions or on loose roadway surfaces, the ability to maneuver will be reduced. All of your actions should be smooth under these conditions. Sudden acceleration, braking or turning may cause loss of control.

When the roadway is wet, rely more on the throttle to control vehicle speed and less on the front and rear brakes.

The throttle should also be used judiciously to avoid skidding the rear wheel from too rapid acceleration or deceleration.

On rough roads, exercise caution, slow down, and grip the fuel tank with your knees for better stability.

When quick acceleration is necessary as in passing, shift to a lower gear to obtain the necessary power.

Do not down shift at too high an r.p.m. to avoid damage to the engine from overrevving.

Avoiding unnecessary weaving is important to the safety of both the rider and other motorists.

Do not exceed the legal speed limit or drive too fast for existing conditions. High speed increases the influence of any condition affecting stability and the loss of control.

Operate motorcycle only at moderate speed and out of traffic until you have become thoroughly familiar with its operation and handling characteristics under all conditions. This is a very high performance motorcycle, designed and intended for use by experienced careful riders only!

A new motorcycle must be operated according to a special break-in procedure (see Running in recommendations).



Warning

Before starting engine, check for proper operation of brake, clutch, shifter, throttle controls, correct fuel and oil supply.

Gasoline is extremely flammable and is explosive under certain conditions. Refuell in a well ventilated area with the engine stopped. Do not smoke or allow open flames or sparks when refuelling or servicing the fuel system. Always

close the fuel petcock when the engine is not running to prevent flooding of the throttle body. Do not overfill fuel tank (see instructions page 53).

Motorcycle exhaust contains poisonous carbon monoxide gas. Do not inhale exhaust gases and never run the engine in a closed garage or confined area.

Use only Ducati approved parts and accessories.

This motorcycle was not intended to be equipped with a sidecar or to be used to tow any trailer or other vehicle.

Ducati does not manufacture sidecars or trailers and cannot predict the effects of such accessories on handling or stability, but can only warn that the effects will be adverse and any damage to motorcycle components caused by the use of such accessories will not be remedied under warranty.



Warning

Do not ride the motorcycle with helmets attached to the hook; the helmets could cause an accident by distracting the operator or interfering with normal vehicle operation.

Protective apparel

Always wear a helmet. Most motorcycle accident fatalities are due to head injuries.

For safety eye protection, gloves, and high top, sturdy boots should also be worn.

The exhaust system becomes very hot during operation, never touch the exhaust system. Wear clothing that fully covers your legs. Do not wear loose clothing which could catch on the control levers, footrests, wheels, or chain.

Any amount of alcohol will significantly interfere with your ability to safely operate your motorcycle. Don't drink and ride.

Vehicle identification number (VIN)

Every Ducati motorcycle is identified by two identification numbers (see page 10). Figure A specifically shows the frame identification numbers.

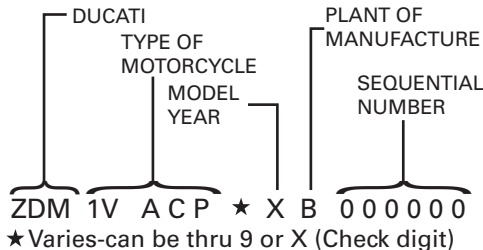

fig. A

Label location (fig. B)

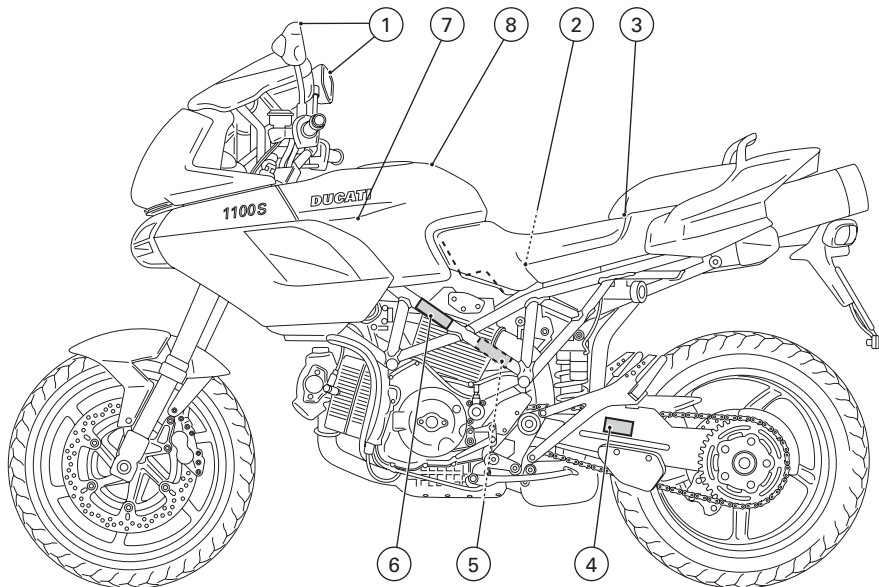
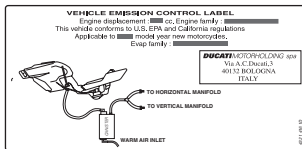

fig. B

OBJECT IN MIRROR ARE
CLOSER THAN THEY APPEAR

1



2

HELMET HOLDER
UNDER THE SEAT

3

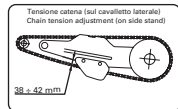

4

MOTORCYCLE NOISE EMISSION CONTROL INFORMATION

THIS xxxxx MOTORCYCLE xxxxxxxx000001
MEETS EPA NOISE EMISSION REQUIREMENTS OF xx dB(A) AT xxxxx RPM BY THE
FEDERAL TEST PROCEDURE.
MODIFICATIONS WHICH CAUSE THIS MOTORCYCLE TO EXCEED FEDERAL NOISE
STANDARDS ARE PROHIBITED BY FEDERAL LAW.
SEE OWNER'S MANUAL

432.1.00x.1A

5

MANUFACTURED BY / FABRIQUÉ PAR: **DUCATI MOTORHOLDING spa**
TYPE OF VEHICLE / TYPE DE VÉHICULE: **MC** DATE: **xx/xxxx**
GVWR / PNBV: **x x x KG** VIN / NIV: **ZDMxxxxxxx000001**

GAWR PNBE KG	TIRE/PNEU - DIMENSION - RIM/JANTE	COLD INFL. PRESS. PRESS. DE GONFL. A FROID PSI / LPC
xxxx xxx	x x x/x x Zr17 x x x/x x Zr17	MT x x x x MT x x x x xx,x xx,x xxx xxx

THIS VEHICLE CONFORMS TO ALL APPLICABLE STANDARDS PRESCRIBED UNDER THE CANADIAN
MOTOR VEHICLE SAFETY REGULATIONS IN EFFECT ON THE DATE OF MANUFACTURE.
CE VÉHICULE EST CONFORME À TOUTES LES NORMES QUI LUI SONT APPLICABLES EN VERTU DU
RÈGLEMENT SUR LA SÉCURITÉ DES VÉHICULES AUTOMOBILES DU CANADA EN VIGUEUR À LA
DATE DE SA FABRICATION.

432.1.00x.1F

6 (Only Canada)

Manufactured by: **DUCATI MOTORHOLDING spa** DATE: **XX/XXXX**
GVWR: xxx Lbs (xxx kg)
GAWR F: xxx Lbs (xxx kg) with xxxxxx ZR tire, xxxxxxxx rim at xxx PSI cold
GAWR R: xxx Lbs (xxx kg) with xxxxxx ZR tire, xxxxxxxx rim at xxx PSI cold
This vehicle conforms to all applicable Federal Motor Vehicle Standards in effect on the
date of manufacture shown above. Type classification: Motorcycle
Vehicle I.D. No. **ZDMXXXXXXXXXXXXXX** 432.1.00x.1B

6

VEHICLE EMISSION CONTROL INFORMATION

Engine displacement: xxx cc
Engine family: xxxxxxxx
Engine exhaust control system:
SFI, 2 TWC and 1 HO2S
Evap family: xxxxxxxx
Permutation family: xxxxxxxxxx

THIS VEHICLE CONFORMS TO U.S. EPA AND
CALIFORNIA REGULATIONS APPLICABLE TO 20xx
MODEL YEAR NEW MOTORCYCLES AND IS
CERTIFIED TO 6.8 HC+NOx GAKM ENGINE FAMILY
EXHAUST EMISSION STANDARD IN CALIFORNIA

ENGINE TUNEUP SPECIFICATIONS

ITEM	SPECIFICATIONS	INSTRUCTIONS
IGNITION TIMING	±°TDC at idle speed	No adjustments
IDLE SPEED (RPM)	xxxx ± xxx	No adjustments
IDLE MIXTURE	Opening x.xx ~ x.xx mm	No adjustments
VALVE CLEARANCE (in & ex)	Closing x.xx ~ x.xx mm	See Service Manual
SPARK PLUG: xxxxxxxxxxxxxxxxxxxx		OIL: xxxxxxxxxxxx
SPARK PLUG GAP (mm): x.x ~ x.x mm		FUEL: Unleaded gasoline
DUCATI MOTORHOLDING spa - Bologna - Italy		
Importer: DUCATI North America Inc. - Cupertino - California		

7

CAUTION

NEVER FILL TANK SO FUEL LEVEL RISES INTO FILLER
NECK. IF TANK IS OVERFILLED, HEAT MAY CAUSE
FUEL TO EXPAND AND FLOW INTO EVAPORATIVE
EMISSION CONTROL SYSTEM RESULTING IN HARD
STARTING AND ENGINE HESITATION.

8

California evaporation emission system

This system consists of (fig. C):

- 1) Warm air inlet;
- 2) Canister;
- 3) Dell'Orto jet;
- 4) Intake manifolds;
- 5) Breather pipe;
- 6) Fuel tank.



Important

In the event of fuel system malfunction, contact Ducati's authorized Service Centres.

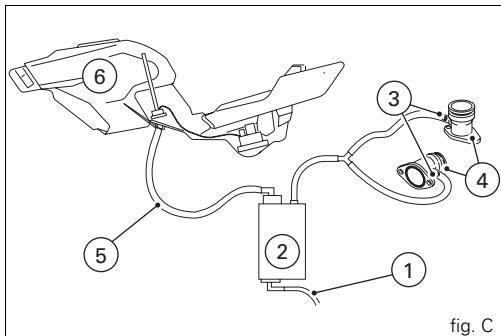

fig. C

Ducati limited warranty on emission control system

Ducati North America, Inc., 10443 Bandy Drive, Cupertino, California, 95014 warrants that each new 1998 and later Ducati motorcycle, that includes as standard equipment a headlight, tail-light and stoplight, and is street legal:

A) is designed, built and equipped so as to conform at the time of initial retail purchase with all applicable regulations of the United States Environmental Protection Agency, and the California Air Resources Board; and
B) is free from defects in material and workmanship which cause such motorcycle to fail to conform with applicable regulations of the United States Environmental Protection Agency or the California Air Resources Board for a period of use, 30,000 kilometers (18,641 miles); or 5 (five) years from the date of initial retail delivery, whichever first occurs.

I. Coverage

Warranty defects shall be remedied during customary business hours at any authorized Ducati motorcycle dealer located within the United States of America in compliance with the Clean Air Act and applicable regulations of the United States Environmental Protection Agency and the California Air Resources Board. Any part or parts replaced under this warranty shall become the property of Ducati. In the state of California only, emissions related warranted parts are specifically defined by that state's Emissions Warranty Parts List. These warranted parts are: carburetor and internal parts; intake manifold; fuel tank, fuel injection system; spark advance mechanism; crankcase breather; air

cutoff valves; fuel tank cap for evaporative emission controlled vehicles; oil filler cap; pressure control valve; fuel/vapor separator; canister; igniters; breaker governors; ignition coils; ignition wires; ignition points, condensers, and spark plugs if failure occurs prior to the first scheduled replacement, and hoses, clamps, fittings and tubing used directly in these parts. Since emission related parts may vary from model to model, certain models may not contain all of these parts and certain models may contain functionally equivalent parts.

In the state of California only, Emission Control System emergency repairs, as provided for in the California Administrative Code, may be performed by other than an authorized Ducati dealer. An emergency situation occurs when an authorized Ducati dealer is not reasonably available, a part is not available within 30 days, or a repair is not complete within 30 days. Any replacement part can be used in an emergency repair. Ducati will reimburse the owner for the expenses, including diagnosis, not to exceed Ducati's suggested retail price for all warranted parts replaced and labor charges based on Ducati's recommended time allowance for the warranty repair and the geographically appropriate hourly labor rate. The owner may be required to keep receipts and failed parts in order to receive compensation.

II. Limitations

This Emission Control System Warranty shall not cover any of the following:

- A. Repair or replacement required as a result of
- (1) accident,
 - (2) misuse,

(3) repairs improperly performed or replacements improperly installed,

(4) use of replacement parts or accessories not conforming to Ducati specifications which adversely affect performance and/or

(5) use in competitive racing or related events.

B. Inspections, replacement of parts and other services and adjustments required for routine maintenance.

C. Any motorcycle on which odometer mileage has been changed so that actual mileage cannot be readily determined.

III. Limited liability

A. The liability of Ducati under this Emission Control Systems Warranty is limited solely to the remedying of defects in material or workmanship by an authorized Ducati motorcycle dealer at its place of business during customary business hours. This warranty does not cover inconvenience or loss of use of the motorcycle or transportation of the motorcycle to or from the Ducati dealer. Ducati shall not be liable for any other expenses, loss or damage, whether direct, incidental, consequential or exemplary arising in connection with the sale or use of or inability to use the Ducati motorcycle for any purpose. Some states do not allow the exclusion or limitation of any incidental or consequential damages, so the above limitations may not apply to you.

B. No express emission control system warranty is given by Ducati except as specifically set forth herein. Any emission control system warranty implied by law, including any warranty of merchantability or fitness for a particular purpose, is limited to the express emission control systems warranty terms stated in this warranty. The foregoing

statements of warranty are exclusive and in lieu of all other remedies. Some states do not allow limitations on how long an implied warranty lasts so the above limitation may not apply to you.

C. No dealer is authorized to modify this Ducati Limited Emission Control Systems Warranty.

IV. Legal rights

This warranty gives you specific legal rights, and you may also have other rights which vary from state to state.

V. This warranty is in addition to the Ducati limited motorcycle warranty.

VI. Additional information

Any replacement part that is equivalent in performance and durability may be used in the performance of any maintenance or repairs. However, Ducati is not liable for these parts. The owner is responsible for the performance of all required maintenance. Such maintenance may be performed at a service establishment or by any individual. The warranty period begins on the date the motorcycle is delivered to an ultimate purchaser.

Ducati North America, Inc.
10443 Bandlely Drive
Cupertino, California, 95014
Tel: 001.408.253.0499
Fax: 001.408.253.4099
E-mail: customerservice@ducatiusa.com
Web site: www.ducatiusa.com

Routine maintenance record

Km/mi	Ducati Service Name	Mileage	Date
1,000/600			
12,000/7,500			
24,000/15,000			
36,000/22,500			
48,000/30,000			
60,000/37,500			

Stampato 05/2008

Cod. 913.7.138.1E

DUCATI 

Ducati Motor Holding spa via Cavalieri Ducati, 3 40132 Bologna, Italia
Tel. +39 051 6413111 Fax +39 051 406580
www.ducati.com

DUCATI 

Ducati Motor Holding spa via Cavalieri Ducati, 3 40132 Bologna, Italia
Tel. +39 051 6413111 Fax +39 051 406580
www.ducati.com